

PARTS CATALOG - CATALOGUE PIECES DE RECHANGE - ERSATZTEILKATALOG - RICAMBIO - PARTI DI RICAMBIO



WRE-SMS 125/2011

Ed. 11-2010



PARTS CATALOG - CATALOGUE PIECES DE RECHANGE - ERSATZTEILKATALOG - RICAMBIO - PARTI DI RICAMBIO

INFORMAZIONI GENERALI

Il presente catalogo serve per richiedere con esattezza le parti di ricambio
Nelle ordinazioni indicare:

- 1) il numero di codice dei particolari seguito dalla descrizione;
- 2) il colore per i pezzi verniciati o comunque colorati;
- 3) il numero di matricola del motociclo, stampigliato sul canotto di sterzo.

Le indicazioni destra e sinistra si riferiscono ai lati del veicolo rispetto al senso di marcia;

GENERAL INFORMATION

The present spare parts list enables one to order exactly the right spare parts.
When ordering specify:

- 1) the part's code number followed by its description;
- 2) indicate colour for painted or coloured parts;
- 3) the motorcycle's serial number, stamped on the steering head.

References to right and left apply to the vehicle in terms of its direction of movement.

INFORMATIONS GENERALES

Ce catalogue permet de commander correctement les pièces de rechange.
Les commandes doivent être passées en indiquant:

- 1) le numéro de code des pièces détachées suivi de leur description;
- 2) le couleur des pièces peintes ou colorés;
- 3) le matricule de la moto, estampillé sur la tige du guidon.

Droite et gauche sont les côtés du véhicule par rapport au sens de la marche.

ALLGEMEINE HINWEISE

Dieser Ersatzteilkatalog dient zur genauen Angabe der Teile bei Ersatzteilbestellungen.

Bei Ersatzbestellung ist folgendes anzugeben:

- 1) Die Bestellnummer der Ersatzteile mit der entsprechenden Beschreibung;
- 2) Farbe für lackierte und farbige Teile angeben;
- 3) Die Sseriennummer des Motorrrads, die am Lenkrohr eingepägt ist.

Die Angaben rechts und links beziehen sich auf das Fahrzeug in Fahrriichtung.

INFORMACIONES GENERALES

El presente catálogo sirve para pedir con exactitud las partes de recambio.
En los pedidos se debe indicar:

- 1) el número de código de la parte y a continuación la descripción;
- 2) el color para las piezas barnizadas o coloreadas;
- 3) el número de matrícula de la motocicleta, estampado en el tubo de dirección. Las indicaciones derecha e izquierda se refieren a los lados del vehículo respecto del sentido de marcha.

NOTE - LIST - NOTES - NOTE - NOTAS:

- A** : In alternativa - In alternative - En alternative - Wahlweise - En alternativa
C : Fornire in coppia - Delivered by pairs - Livrées par paire - Paarweise Geliefert
 Livrées par paire
D : In dotazione - To issue - En nécessaire - Ausrüstungsteile - En dotación
E : Ad esaurimento - To fell out - A' finir - Erschöpfung - A agotamiento
F : Fornire assieme - Supply unitedly - Fournir ensemble - Wird zusammen
 geliefert - Equipar juntos
H : Contenuto in busta guarnizioni - It's contained in the gasket set
 Contenu entre l'enveloppe du joints - In den Reparaturendichtungssatz
 Se encuentra en la bolsa de guarniciones
M : Modello SMS- SMS model - Modèle SMS- Modell SMS - Modelo SMS
N : Non fornito - Not supplied - Ne pas fournit - Keine Gelieferende - No equiparado
R : A richiesta - Upon request - Sur demande - Auf anfrage - a pedimento
S : Di serie - Supplied - De série - Standard - De serie
U : Versione HERMUNEN - HERMUNEN version - Version HERMUNEN - Ausführung
 HERMUNEN - Versión HERMUNEN
W : Modello WRE- WRE model - Modèle WRE- Modell WRE- Modelo WRE
Z : n° denti, number of teeth, numéro dents, Zähne nummer - número dientes

- A** : Austria, Austria, Autriche, Österreich, Austria
AUS : Australia, Australia, Australie, Australien, Australia
B : Belgio, Belgium, Belgique, Belgien, Bélgica
BR : Brasile, Brazil, Brasile, Brasilien, Brasil
CDN : Canada, Canada, Canada, Kanada, Canadá
CH : Svizzera, Switzerland, Suisse, Schweizer, Suiza
D : Germania, Germany, Allemagne, Deutschland, Alemania
E : Spagna, Spain, Espagne, Spanien, España
F : Francia, France, France, Frankreich, Francia
GB : Gran Bretagna, Great Britain, Grand Bretagne, Groos Britan, Gran Bretaña
I : Italia, Italy, Italie, Italien, Italia
J : Giappone, Japan, Japon, Japan, Japón
SF : Finlandia, Finald, Finlande, Finnland, Finlandia
USA : Stati Uniti d'America, United States of America, Etats Units d'Amerique,
 Vereinigte Staaten von Amerika, Estados Unidos

Dati indicativi soggetti a modifiche senza impegno di preavviso.

All data are subject to modification without prior notice.

Données indicatif sujet au modifications sans obligation de préavis.

Anderungen Vorbehalten.

Datos indicativos sujetos a modificaciones sin compromiso de preaviso.

N° DI MATRICOLA INIZIALE - INITIAL SERIAL NUMBER - MATRICULE INITIAL - BEGINNTESERIENNUMMER - MATRICULA INICIAL	
MODELLO - MODEL MODELE - MODELL MODELO	MATRICOLA - SERIAL NUMBER MATRICULE - SERIENNUMMER MATRICULA
WRE 125	ZKHH200AABV000001
SMS 125	ZKHH200ABV000001

Tavola Drawing Table Bild Tabla	Denominazione	Description	Designation	Bezeichnung	Denominacion	Pagina Page Seite Seite Paja
1	ATTREZZI DI ASSISTENZA,MANUALI, CATALOGHI , KIT	SERVICE TOOLS, MANUALS, CATALOGS, KIT	OUTILS D'ASSISTANCE, MANUELS, CATALOGUES, KIT	HILFAUSRUSTUNG, HANDBUCH, KATALOG, KIT	HERRAMIENTAS DE ASISTENCIA, MANUALES, CATALOGOS, KIT	13
2	TESTA CILINDRO, PISTONE, MANOVELLISMO	CYLINDER HEAD, CYLINDER, PISTON, CRANKSHAFT	CULASSE, CYLINDRE, PISTON, VILEBREQUIN	ZYLINDERKOPF, ZYLINDER, KOLBEN, KURBELWELLE	CULATA, CILINDRO, PISTON, PALANCAS	15
3	H.T.S.	H.T.S.	H.T.S.	H.T.S.	H.T.S.	21
4	RAFFREDDAMENTO	COOLING	REFROIDISSEMENT	WASSERKÜHLUNG	ENFRIAMIENTO	25
5	BASAMENTO	CRANKCASE	CARTER	GEHAUSE	BANCADA	29
6	COPERCHI BASAMENTO	CRANKCASE COVERS	COUVERCLES CARTER	GEHAUSEDECKEL	TAPA BANCADA	33
7	FRIZIONE, TRASMISSIONE PRIMARIA	CLUTCH, PRIMARY DRIVE	EMBRAYAGE, TRANSMISS. PRIMARIE	KUPPLUNG, ERSTERANTRIEB	EMBRAGUE, TRANSM. PRIMARIA	35
8	CAMBIO	TRANSMISSION	BOITE DE VITESSE	WECHSELGETRIEBE	CAMBIO	37
9	COMANDO CAMBIO	SHIFTER	COMMANDE DE VITESSE	GANGSCHALTUNG	MANDO CAMBIO	41
10	LUBRIFICAZIONE	OIL PUMP AND DRIVE	PUMPE HUILE	MOTORSHMIERUNG	LUBRICATION	43
11	PARTE ELETTRICA	ELECTRIC PART	PARTIE ELECTRIQUES	ELEKTRISCHETEILE	PARTE ELECTR.	45
11A	AVVIAMENTO A PEDALE	KICK STARTER	PEDAL DE MISE EN MARCHE	ANLASSER	PUESTA EN MARCHA A PEDAL	47
12	CARBURATORE, VALVOLA SOLENOIDE	CARBURETOR, SOLENOID VALVE	CARBURATEUR , SOUPAPE SOLÉNOIDE	VERGASER, SOLENOID SICHERUNG	CARBURADOR, VÁLVULA SOLENOIDE	49
13	FILTRO ARIA	AIR FILTER	FILTRE AIRE	AIRFILTER	FILTRO DE AIRE	53
14	TELAIO, PEDANE	FRAME, FOOT RESTS	CADRE, REPOSE PIEDS	RAHMEN, FUSSBRETT	BASTIDOR, REPOSAPIES	55
15	SOSPENSIONE ANTERIORE	FRONT FORK ASSEMBLY	SUSPENSION AVANT	VORDETELESKOPGABEL	SUSPENSION DELANTERA	59
15A	SOSPENSIONE ANTERIORE HERMUNEN	FRONT FORK ASSEMBLY HERMUNEN	SUSPENSION AVANT HERMUNEN	VORDETELESKOPGABEL HERMUNEN	SUSPENSION DELANTERA HERMUNEN	63
16	FORCELLONE	SWING ARM	FOURCHE	GABEL	HORQUILLA	67
16A	LEVERAGGI SOSPENSIONE POST.	REAR SUSPENSION LINKAGE	LEVIER SUSPENSION ARRIERE	HEBELWERK HINTERHAUFHANGUNG	PALANCA SUSPENSION TRASERA	71
16B	AMMORTIZZATORE POSTERIORE	REAR SUSPENSION	SUSPENSION ARRIÈRE	HINTERHAUFHANGUNG	SUSPENSION TRASERA	73
17	MANUBRIO E COMANDI	HANDLEBAR AND CONTROLS	GUIDON ET COMMANDES	LENKER UND STEUERORGANE	MANILLAR Y MANDOS	75
18	FRENO IDRAULICO POSTERIORE	REAR HYDRAULIC BRAKE	FREIN HYDRAULIQUE ARRIERE	HINTERBREMSE	FRENO HIDRAULICO TRASERO	77
19	PANNELLI LAT., PARAFANGHI, SELLA	SIDE PANELS, FENDERS, SEAT	PANNEAU, GARDE-BOUES , SIEGE	STREIFEN, KOTFLUGEL, SATTEL	PANELES, GUARDABARROS, SILLIN	79
19A	PANNELLI LAT., PARAFANGHI, SELLA HERMUNEN	SIDE PANELS, FENDERS, SEAT HERMUNEN	PANNEAU, GARDE-BOUES , SIEGE HERMUNEN	STREIFEN, KOTFLUGEL, SATTEL HERMUNEN	PANELES, GUARDABARROS, SILLIN HERMUNEN	83
20	SERBATOIO, CONVOGLIATORI	GAS TANK, SPOILERS	RESERVOIR, FLANC	KRAFTSTOFFBEHALTER, FLANKEN	DEPOSITO, LATERALES	85
20A	SERBATOIO, CONVOGLIATORI HERMUNEN	GAS TANK, SPOILERS HERMUNEN	RESERVOIR, FLANC HERMUNEN	KRAFTSTOFFBEHALTER, FLANKEN HERMUNEN	DEPOSITO, LATERALES HERMUNEN	87
21	SCARICO	EXHAUST SYSTEM	TUYAU D'ÉCHAPPEMENT	AUSPUFFROHR	TUBO DE ESCAPE	89
22	FRENO IDRAULICO ANTERIORE	FRONT HYDRAULIC BRAKE	FREIN HYDRAULIQUE AVANT	VORTERBREMSE	FRENO HIDRAULICO DELANTERO	91
22A	RUOTA ANTERIORE	FRONT WHEEL	ROUE AV.	VORTERRAD	RUEDA DELANTERA	93

Tavola - Drawing - Table - Bild - Tabla

1

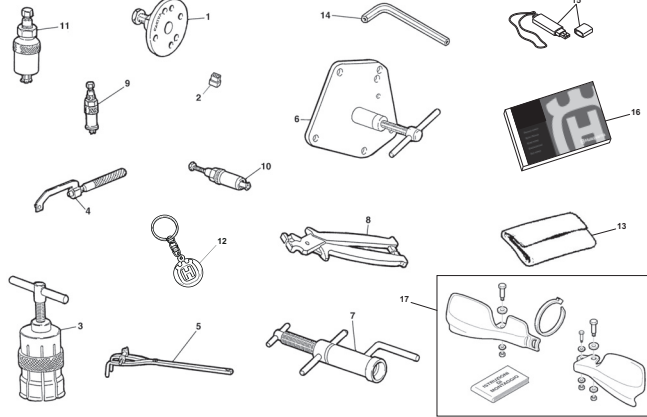

Pagina - Page - Page - Seite - Paja

12

Tavola - Drawing - Table - Bild - Tabla

2

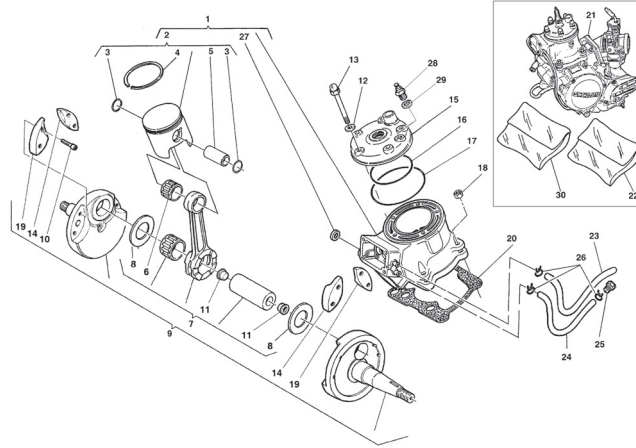

Pagina - Page - Page - Seite - Paja

14

Tavola - Drawing - Table - Bild - Tabla

3

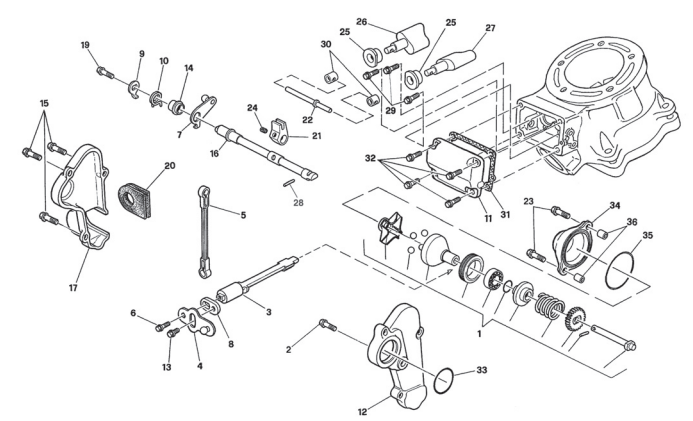

Pagina - Page - Page - Seite - Paja

20

Tavola - Drawing - Table - Bild - Tabla

4

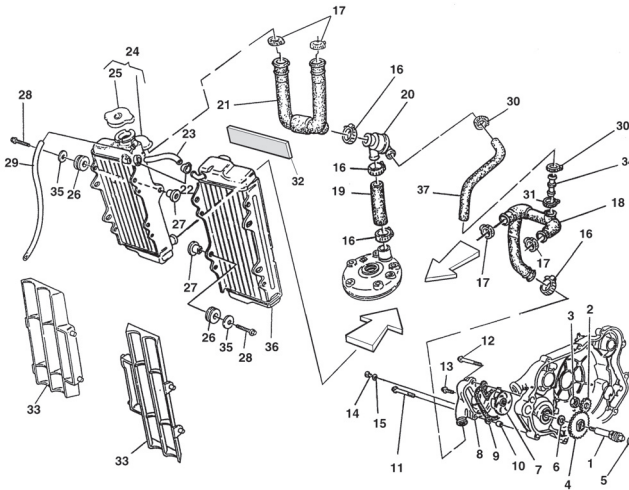

Pagina - Page - Page - Seite - Paja

24

Tavola - Drawing - Table - Bild - Tabla

5

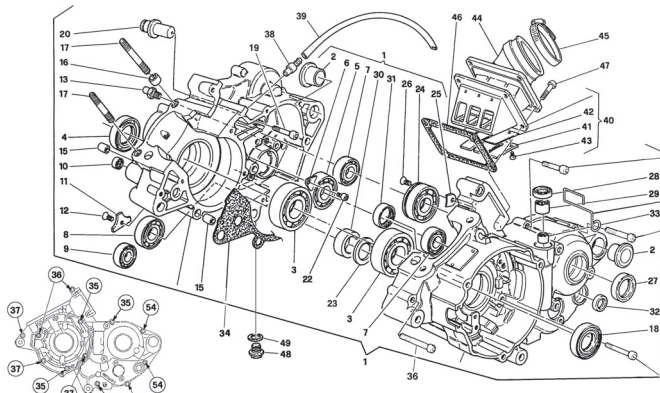

Pagina - Page - Page - Seite - Paja

28

Tavola - Drawing - Table - Bild - Tabla

6

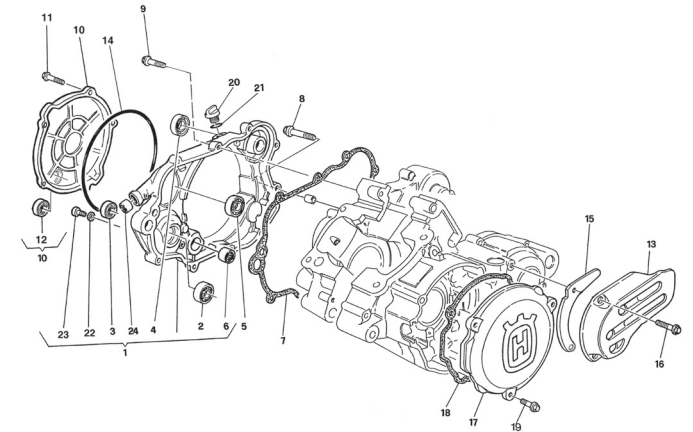

Pagina - Page - Page - Seite - Paja

32

Tavola - Drawing - Table - Bild - Tabla

7

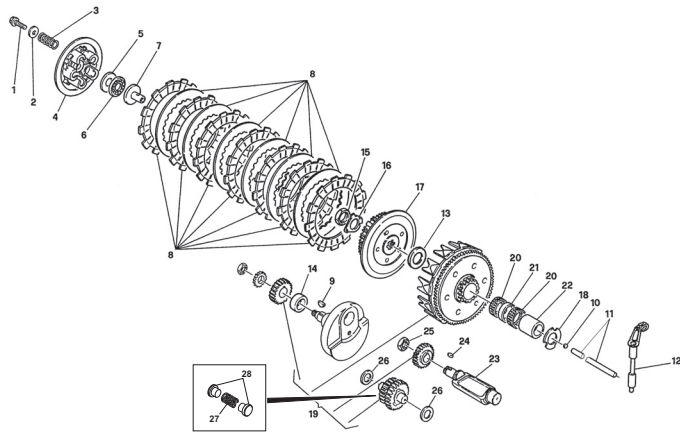

Pagina - Page - Page - Seite - Paja

34

Tavola - Drawing - Table - Bild - Tabla

8

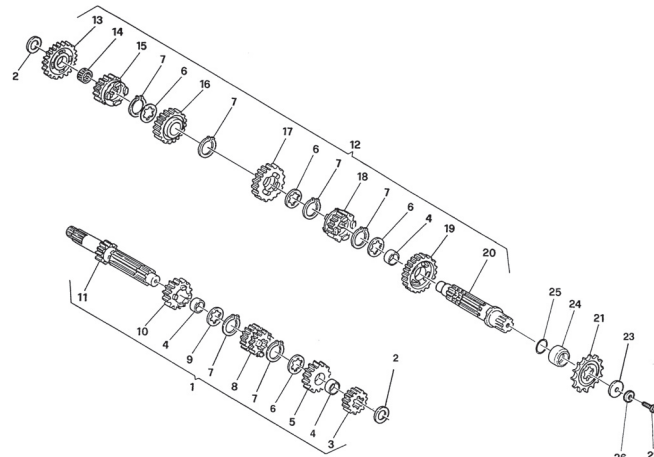

Pagina - Page - Page - Seite - Paja

36

Tavola - Drawing - Table - Bild - Tabla

9

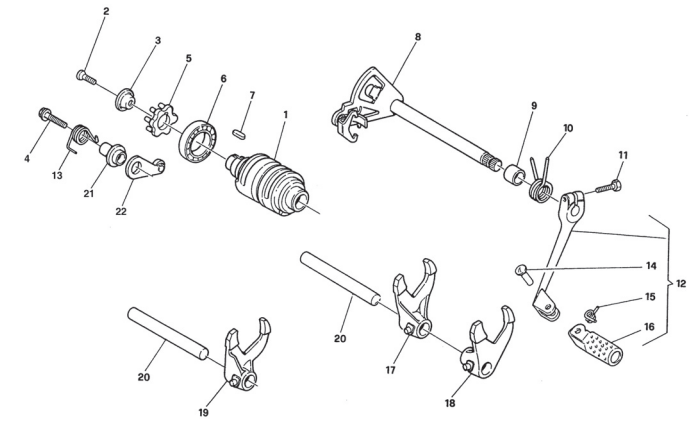

Pagina - Page - Page - Seite - Paja

40

Tavola - Drawing - Table - Bild - Tabla

10

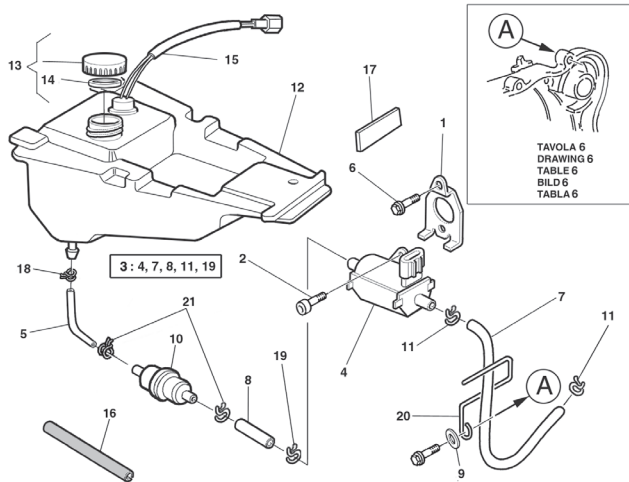

Pagina - Page - Page - Seite - Paja

42

Tavola - Drawing - Table - Bild - Tabla

11

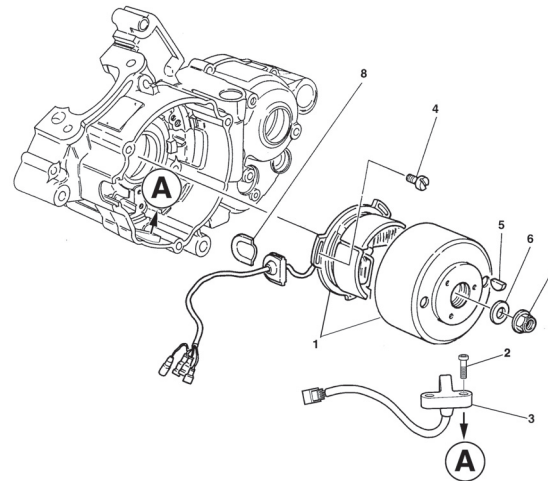

Pagina - Page - Page - Seite - Paja

44

Tavola - Drawing - Table - Bild - Tabla

11A

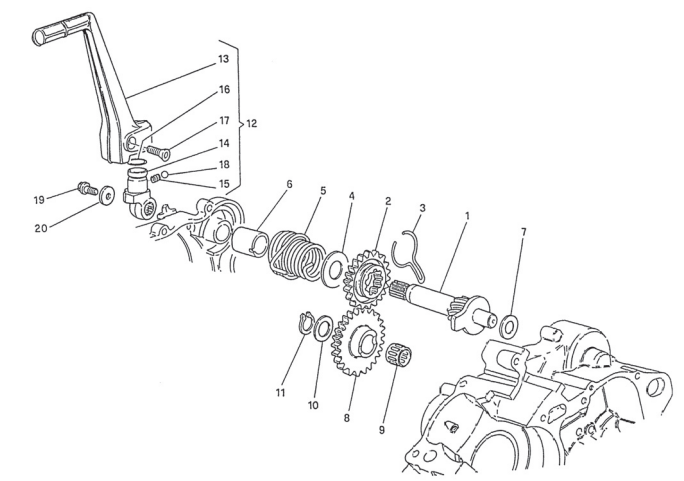

Pagina - Page - Page - Seite - Paja

46

Tavola - Drawing - Table - Bild - Tabla

12

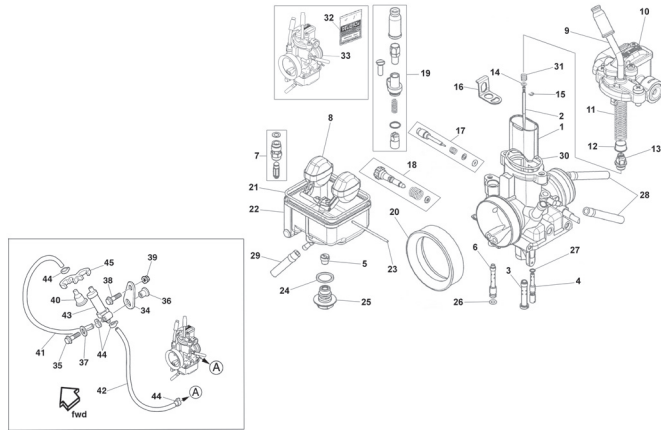

Pagina - Page - Page - Seite - Paja

48

Tavola - Drawing - Table - Bild - Tabla

13

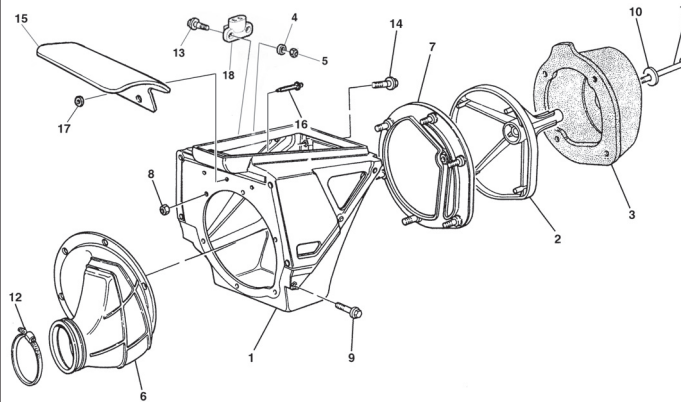

Pagina - Page - Page - Seite - Paja

52

Tavola - Drawing - Table - Bild - Tabla

14

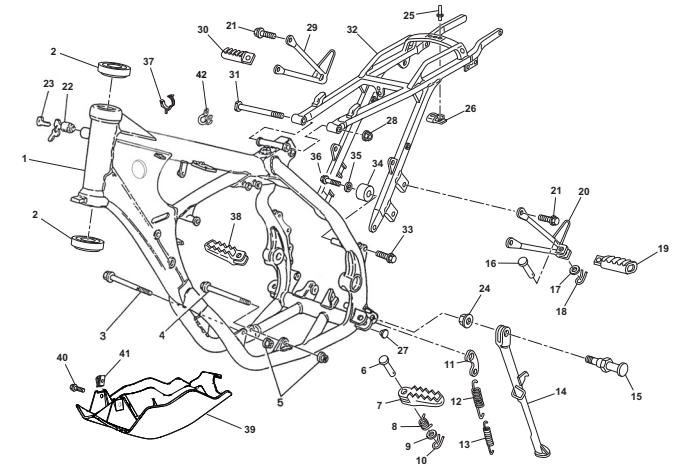

Pagina - Page - Page - Seite - Paja

54

Tavola - Drawing - Table - Bild - Tabla

15

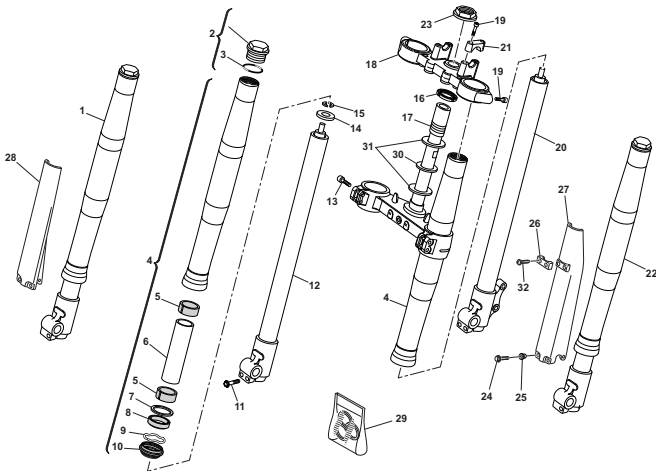

Pagina - Page - Page - Seite - Paja

58

Tavola - Drawing - Table - Bild - Tabla

15A

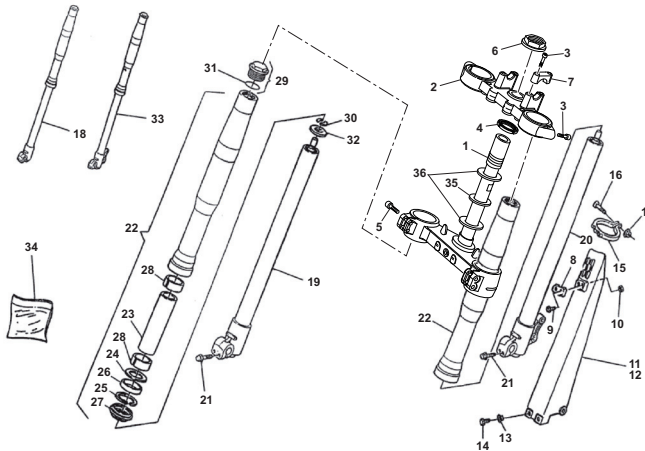

Pagina - Page - Page - Seite - Paja

62

Tavola - Drawing - Table - Bild - Tabla

16

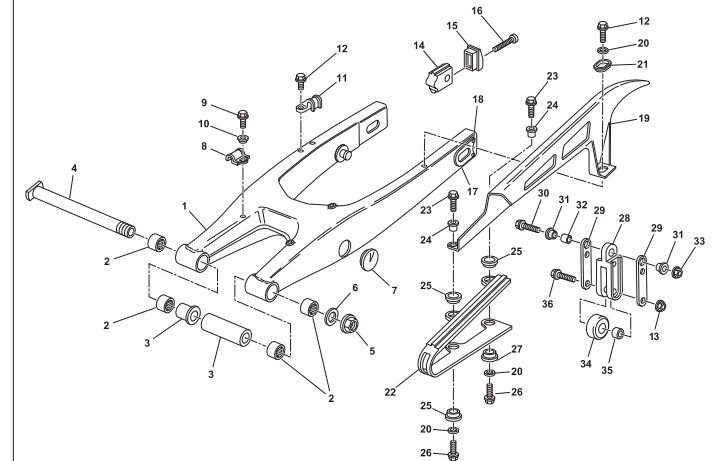

Pagina - Page - Page - Seite - Paja

66

Tavola - Drawing - Table - Bild - Tabla

16A

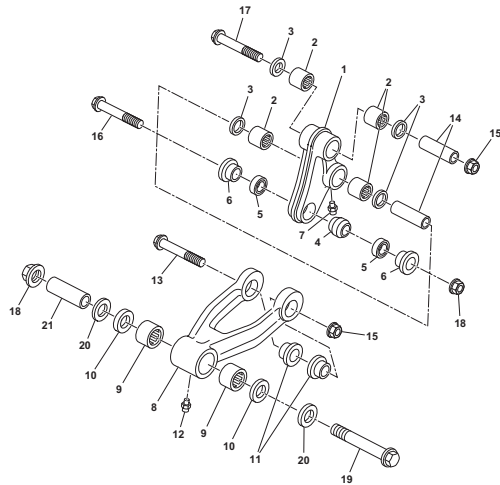

Pagina - Page - Page - Seite - Paja

70

Tavola - Drawing - Table - Bild - Tabla

16B

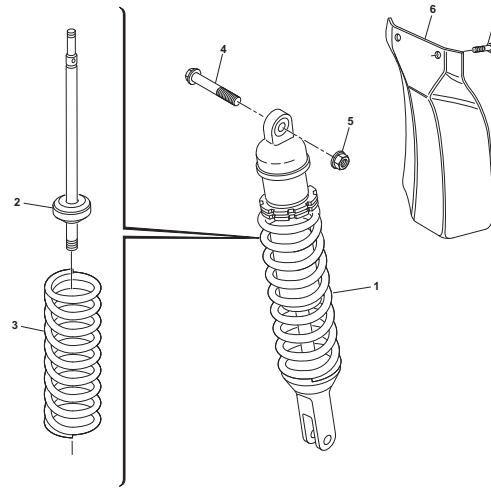

Pagina - Page - Page - Seite - Paja

72

Tavola - Drawing - Table - Bild - Tabla

17

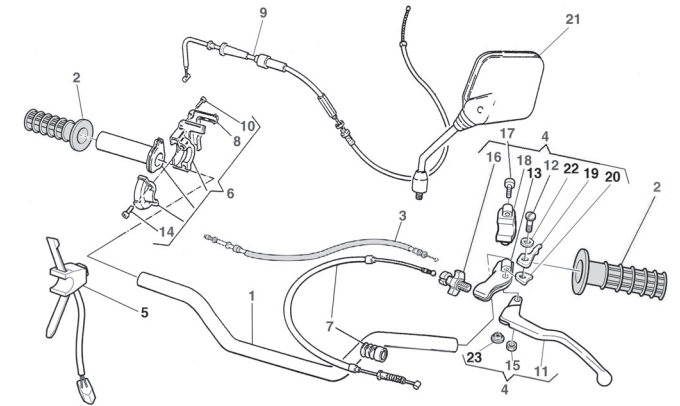

Pagina - Page - Page - Seite - Paja

74

Tavola - Drawing - Table - Bild - Tabla

18

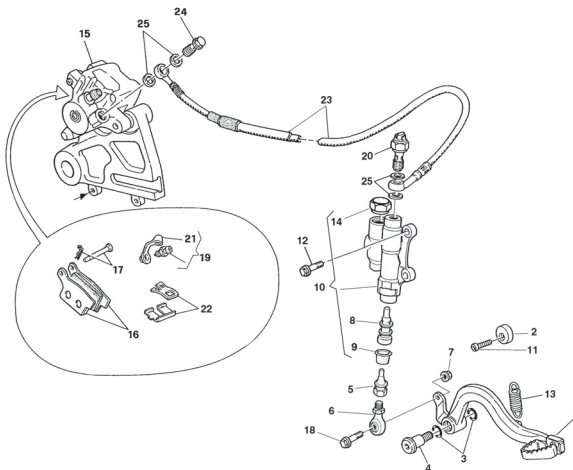

Pagina - Page - Page - Seite - Paja

76

Tavola - Drawing - Table - Bild - Tabla

19

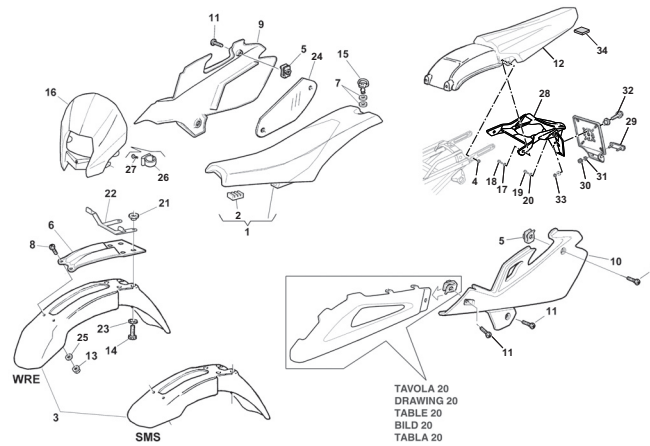

Pagina - Page - Page - Seite - Paja

78

Tavola - Drawing - Table - Bild - Tabla

19A

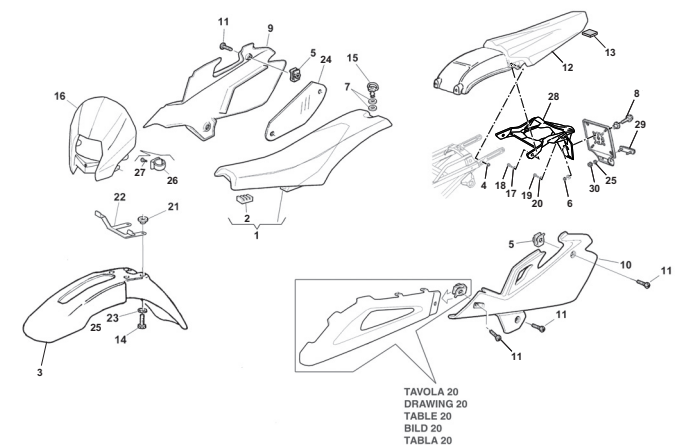

Pagina - Page - Page - Seite - Paja

82

Tavola - Drawing - Table - Bild - Tabla

20

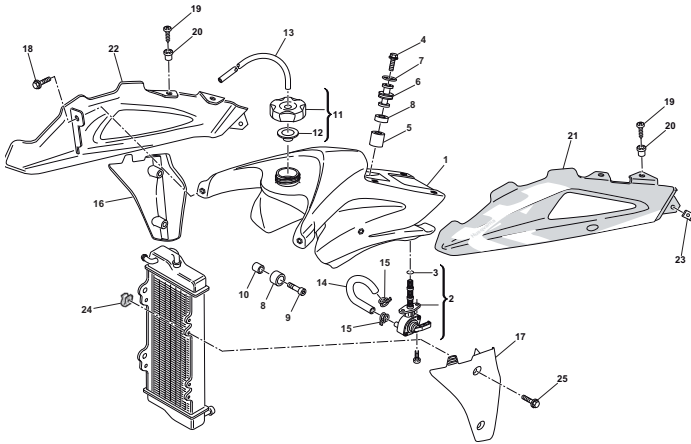

Pagina - Page - Page - Seite - Paja

84

Tavola - Drawing - Table - Bild - Tabla

20A

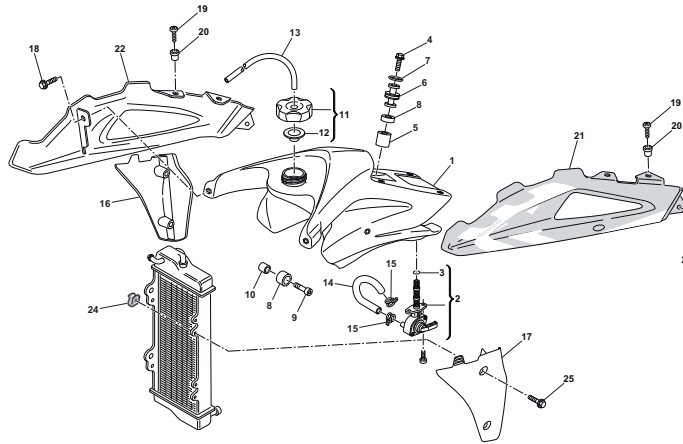

Pagina - Page - Page - Seite - Paja

86

Tavola - Drawing - Table - Bild - Tabla

21

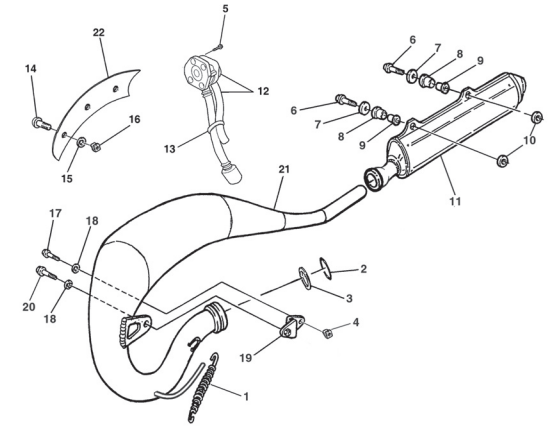

Pagina - Page - Page - Seite - Paja

88

Tavola - Drawing - Table - Bild - Tabla

22

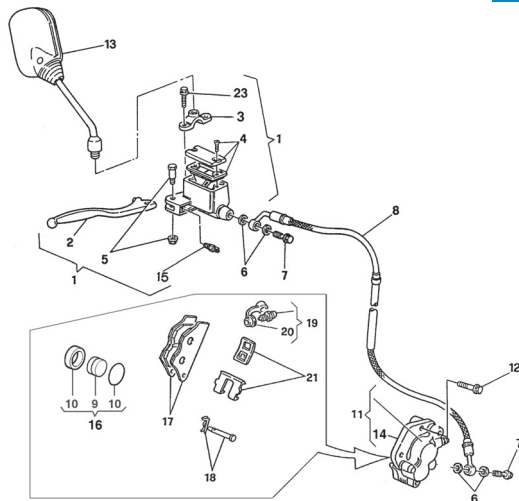

Pagina - Page - Page - Seite - Paja

90

Tavola - Drawing - Table - Bild - Tabla

22A

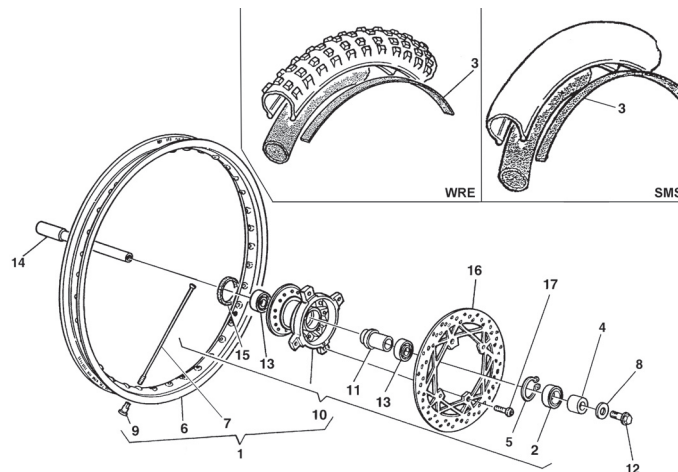

Pagina - Page - Page - Seite - Paja

92

Tavola - Drawing - Table - Bild - Tabla

23

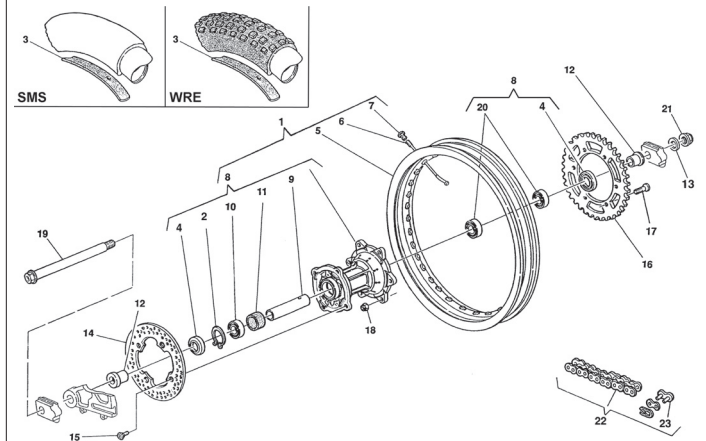

Pagina - Page - Page - Seite - Paja

94

Tavola - Drawing - Table - Bild - Tabla

24

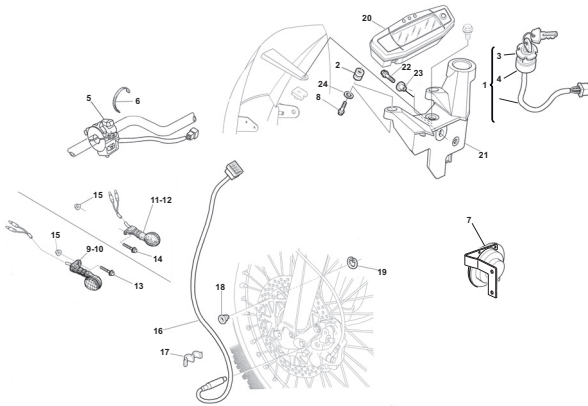

Pagina - Page - Page - Seite - Paja

96

Tavola - Drawing - Table - Bild - Tabla

25

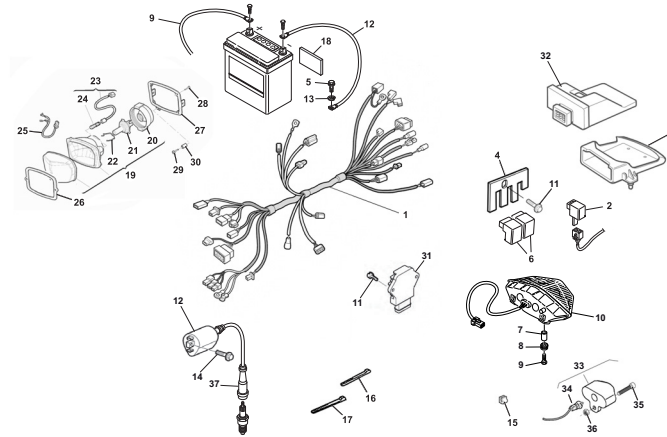

Pagina - Page - Page - Seite - Paja

98

Tavola - Drawing - Table - Bild - Tabla

26



Pagina - Page - Page - Seite - Paja

102

Tavola - Drawing - Table - Bild - Tabla

27



Pagina - Page - Page - Seite - Paja

104

Tavola - Drawing - Table - Bild - Tabla

27A



Pagina - Page - Page - Seite - Paja

106

Tavola - Drawing - Table - Bild - Tabla

27B



Pagina - Page - Page - Seite - Paja

108



**PAGINA INTENZIONALMENTE BIANCA
INTENTIONALLY WHITE PAGE**

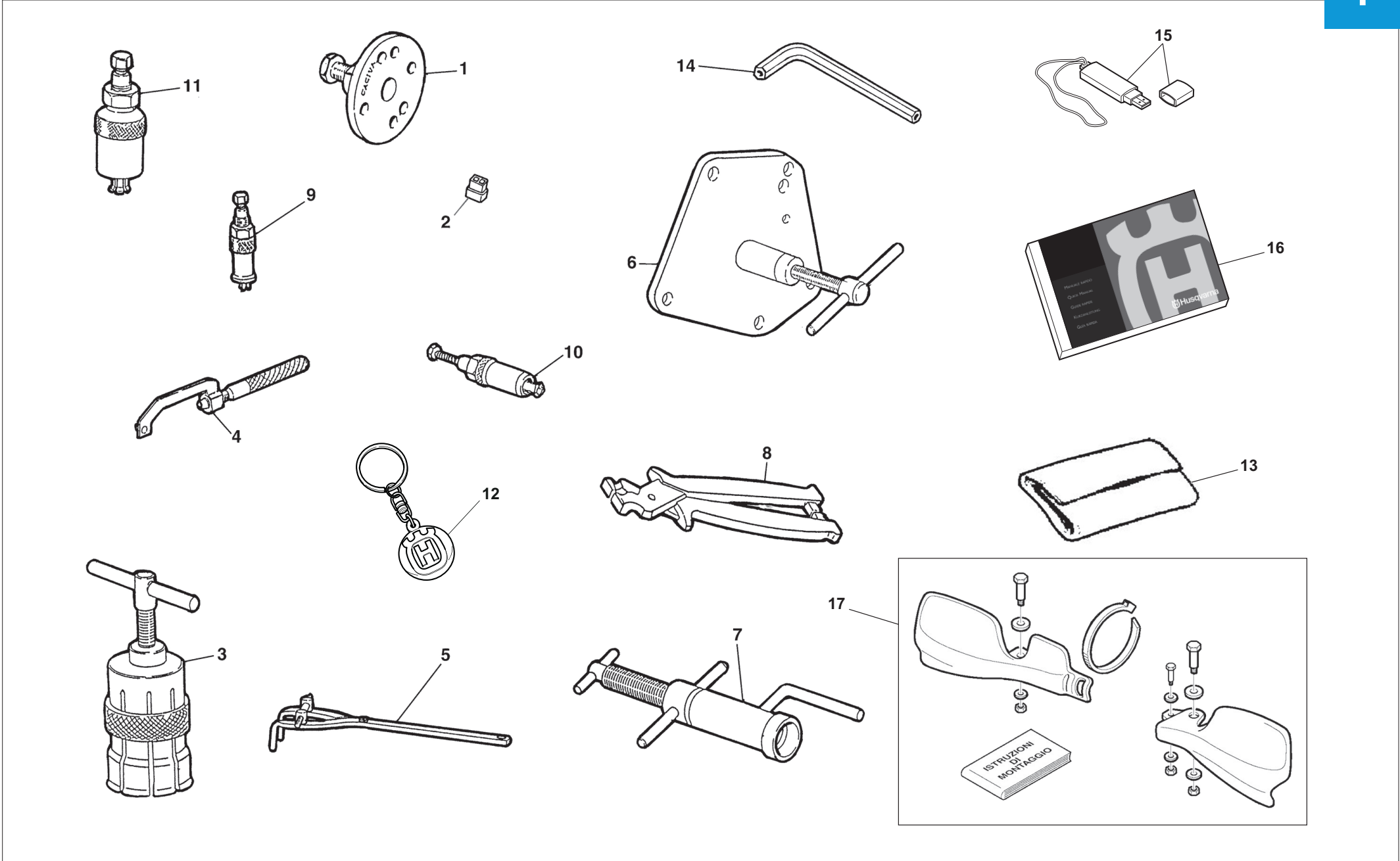



Note Notes Notes Marke Notas	Pos. No. N. Index Pos.	N. Cod. Code No. Nr. Code Code Nr N. Cod.	Q.tà Q.ty Q.te M.ge C.ad	DENOMINAZIONE	NAME	DESIGNATION	BESHREIBUNG	DENOMINACION	Validità Validity Validité Gültig Validez
	1	8000 51614	1	Estrattore volano	Flywheel extractor	Extracteur pour volant	Auszieher für Schwungrad	Extractor volante	
	2	8000 A9751	1	Connettore programmazione centralina	E.C.U. setting connector	Connecteur centrale électronique	Verbindungsstecker für Zundelektronik	Conector centralita electronica	
	3	8000 89030	1	Estrattore per cuscinetto albero motore	Crankshaft bearing extractor	Extracteur pour roulement vilebrequin	Auszieher für Antriebswellelager	Extractor coijnete cigüeñal	
	4	000Y A2273	1	Chiave fermo pignone	Pinion lock wrench	Cléf arrêt pinion	Schlüssel f. ritzelsperrung	Llave parado pinon	
	5	8000 79015	1	Chiave per mozzo frizione	Clutch hub retaining wrench	Cléf arrêt moyeu embrayage	Schlüssel radnabe	Llave cubo friccion	
	6	8000 79016	1	Attrezzo sep. semicarter e smont. albero motore	Crankcase splitting tool and crankshaft disassembly	Outil pour demontage carters et vilebrequin	Werkzeug für Trennung Gehäusehälfte und	Herramienta semi-carter	
	7	8000 79017	1	Attrezzo mont. alb. motore nel carter	Installing tool crankshaft	Outil mont. vilebrequin Gehäuse	Werkzeug zur Mont. Kurbelwelle im demicarter	Herram. mont. eje motore	
	8	8000 49767	1	Pinza montaggio fascette	Clamp installing plier	Pince pour montage collier	Schellenzange	Pinza montaje abrazaderas	
	9	8000 43824	1	Estrattore per cusc. a rullini rinvio comando valvola, cuscinetto pompa acqua e comando valvola	Puller, exhaust valve layshaft needle bearings, water pump shaft ball bear. and exhaust valvedrive regulator ball bear.	Extracteur pour coquillé à aiguille renvoi com. soupape, palier pompe et renvoi com. soupape	Werkzeug für Rollenlager, Vorgelege, Ventilsteuerung Lager, Wasserpumpe und, Vorgelege	Extractor cijnete de rulos mando valvula y bomba agua	
	10	8000 33054	1	Estrattore cuscinetto a rullini albero pompa olio	Needle bearing oil pump shaft extractor	Extrac. pour roulement arbre pompe à huile	Auszieher für Nadelkäfig Oelpumpenwelle	Extrac. cijnete de rodillos eje bomba aceite	
	11	8000 43720	1	Estrattore per cuscinetto albero com. cambio	Puller, gear shifter cam ball bearing	Extracteur pour roulement	Werkzeug für Lager, Scaltwelle	Extractor coijneteje cambio	
	12	HMAK R7AU0	1	Portachiavi	Key-ring	Porte-cléfs	Schlüsselring	Llavero	
	13	8A00 A7171	1	Borsa attrezzi completa	Tool bag assy.	Trousse à outils compl.	Werkzeugtasche Kpl	Bolsa herramientas compl.	
	14	8000 98431	1	Chiave per viti antimanomissione	"Antitampering"screw wrench	Clef pour vis "Antitampering"	"Antitampering" Schraubeschlüssel	Llave por tornillos "Antitampering"	
	15	8000 H5346	1	Chiavetta USB	USB key	Mémoire USB	USB Speicher-stick	Memoria USB	
	16	8000 H5345	1	Quick manual	Quick manual	Guide rapide	Kurzanleitung	Guía rápida	
	17	8000 H5381	1	Kit paramani	Hand guards kit	Kit pare-mains	Kit Handschutz	Kit para manos	
U	17	8000 H6398	1	Kit paramani	Hand guards kit	Kit pare-mains	Kit Handschutz	Kit para manos	

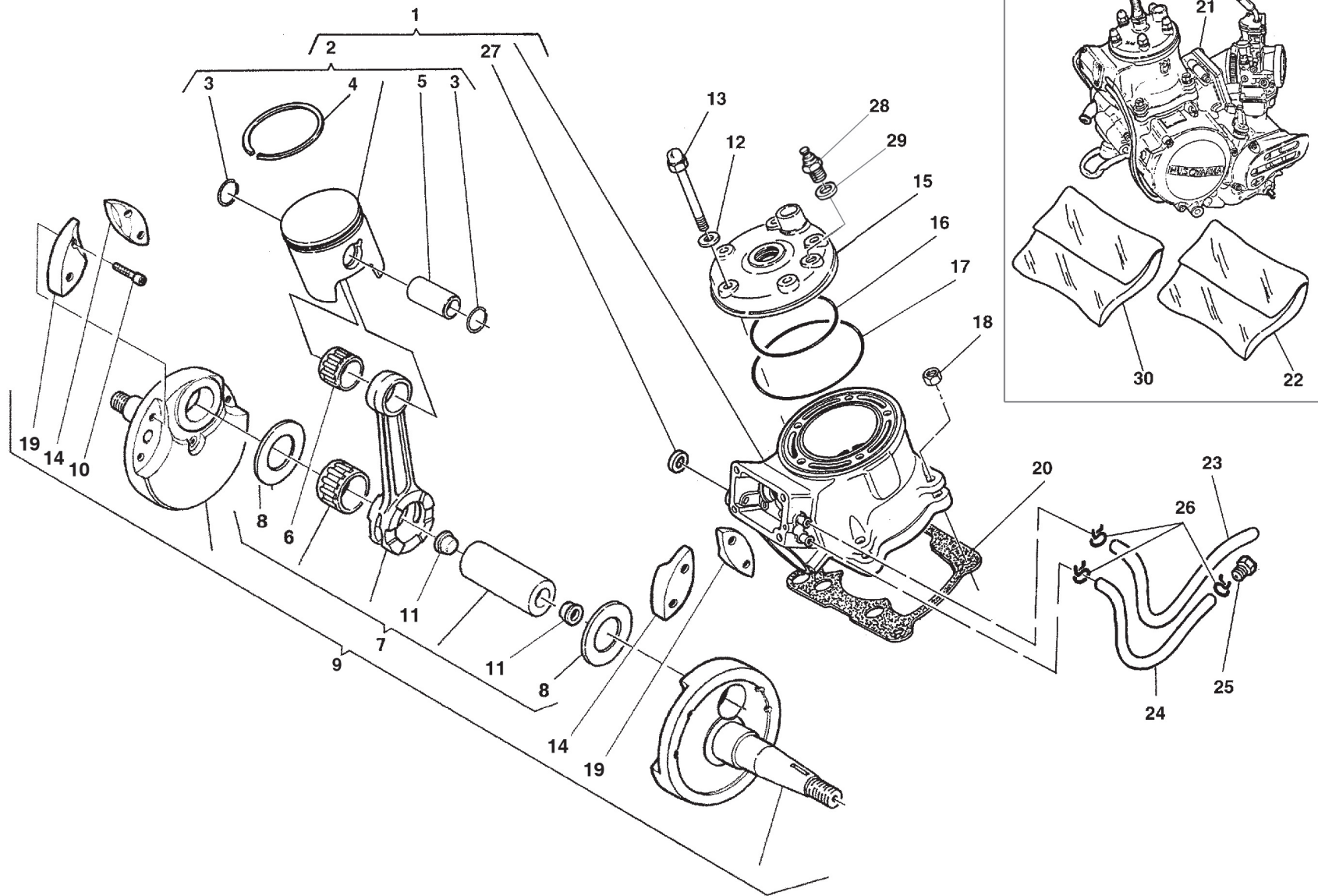



Note Notes Notes Marke Notas	Pos. No. N. Index Pos.	N. Cod. Code No. Nr. Code Code Nr N. Cod.	Q.tà Q.ty Q.te M.ge C.ad	DENOMINAZIONE	NAME	DESIGNATION	BESHREIBUNG	DENOMINACION	Validità Validity Validité Gültig Validez
	1	8000 A1242	1	Cilindro completo	Cylinder assy	Cylindre compl.	Zylinder kpl.	Cilindro compl.	
	2	8000 99749/1	1	Pistone completo	Compl. piston	Piston complet	Kolben, kpl.	Pistón completo	
				A-B (ø 53,940÷53,950 mm)	A-B (ø 53,940÷53,950 mm)	A-B (ø 53,940÷53,950 mm)	A-B (ø 53,940÷53,950 mm)	A-B (ø 53,940÷53,950 mm)	
	2	8000 99749/2	1	Pistone completo	Compl. piston	Piston complet	Kolben, kpl.	Pistón completo	
				C-D (ø 53,950÷53,960 mm)	C-D (ø 53,950÷53,960 mm)	C-D (ø 53,950÷53,960 mm)	C-D (ø 53,950÷53,960 mm)	C-D (ø 53,950÷53,960 mm)	
	2	8000 99749/3	1	Pistone completo	Compl. piston	Piston complet	Kolben, kpl.	Pistón completo	
				E-F (ø 53,960÷53,970 mm)	E-F (ø 53,960÷53,970 mm)	E-F (ø 53,960÷53,970 mm)	E-F (ø 53,960÷53,970 mm)	E-F (ø 53,960÷53,970 mm)	
	3	8000 10314	2	Anellino ritegno spinotto	Circlip	Bague d'arret	Federring	Anillo de retención	
	4	8000 A4506	1	Segmento	Circlip	Segment	Kolbenring	Segmento	
	5	8000 83066	1	Spinotto	Gudgeon	Axe	Bolzen	Perno	
	6	8000 83071	1	Cuscinetto a rullini	Needle bearing	Roulement à aiguilles	Nadelkafig	Cojinete	
	7	8000 88810	1	Biella motore compl.	Connecting rod compl.	Bielle compl.	Pleuelstange kpl.	Biela motor completa	
	8	8000 50629	2	Rosetta	Washer	Rondelle	Scheibe	Arandela	
	9	8000 H0417	1	Compl. albero motore	Crankshaft assy	Vilebrequin compl.	Kurbewelle kpl.	Cigüeñal compl.	
	10	60N1 02486	8	Vite	Screw	Vis	Schraube	Tornillo	
	11	8000 57196	2	Tappo	Plug	Bouchon	Verschluss	Tapón	
	12	8B00 64988	5	Rosetta	Washer	Rondelle	Scheibe	Arandela	
	13	ZK00 69056	5	Vite	Screw	Vis	Schraube	Tornillo	
	14	8000 A8447	2	Inserto	Insert	Insert	Platte	Inserto	
	15	8000 86981	1	Testa cilindro	Cylinder head	Culasse cylindre	Zylinderkopf	Culada cilindro	
	16	8000 39630	1	Anello OR interno	O Ring	Bague OR	O Ring	Anillo OR	
	17	8000 70635	1	Anello OR esterno	O Ring	Bague OR	O Ring	Anillo OR	
	18	Y000 43928	4	Dado frenato	Nut	Ecrou	Mutter	Tuerca	
	19	8000 A8446	2	Inserto	Insert	Insert	Platte	Inserto	
	20	8000 83068	1	Guarnizione (0,3 mm)	Gasket (0,3 mm)	Garnitue (0,3 mm)	Dichtung (0,3 mm)	Junta (0,3 mm)	
	20	8A00 83068	1	Guarnizione (0,4 mm)	Gasket (0,4 mm)	Garnitue (0,4 mm)	Dichtung (0,4 mm)	Junta (0,4 mm)	
	20	8B00 83068	1	Guarnizione (0,5 mm)	Gasket (0,5 mm)	Garnitue (0,5 mm)	Dichtung (0,5 mm)	Junta (0,5 mm)	
	21	8000 H5435	1	Motore completo	Engine assy	Moteur compl.	Motor kpl.	Guepial compl.	
R	22	8000 A8986	1	Gruppo guarnizioni motore	Engine gasket set	Groupe garniture moteur	Dichtunggruppe Motor	Grupo juntas	
	23	8000 83056	1	Tubo sfiato	Pipe	Tuyau	Rohr	Tubo	
	24	8A00 83056	1	Tubo sfiato	Pipe	Tuyau	Rohr	Tubo	
	25	8000 79560	1	Tappo	Plug	Bouchon	Verschluss	Tapón	
	26	8A00 40433	3	Fascetta	Clamp	Collier	Schelle	Banda	

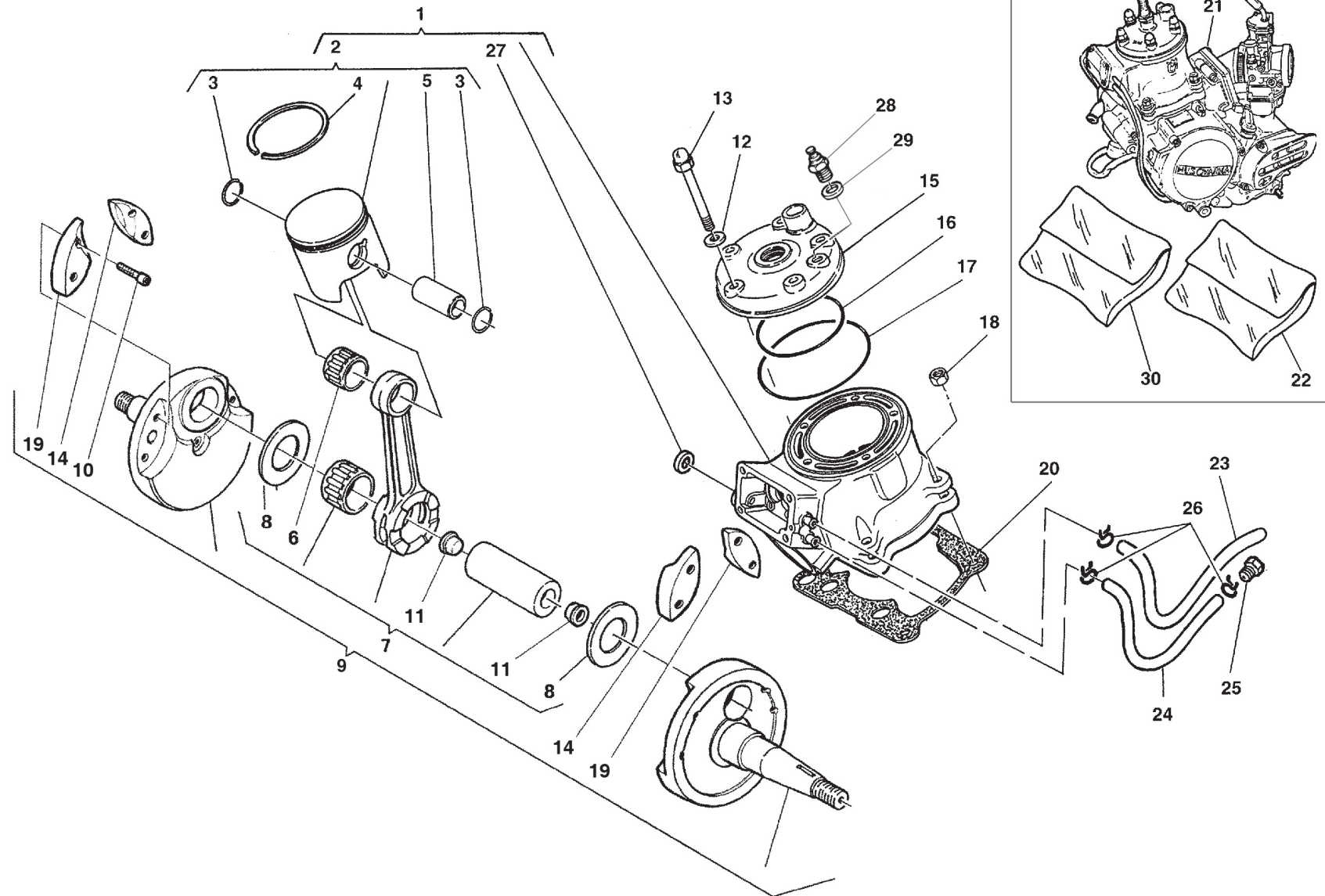

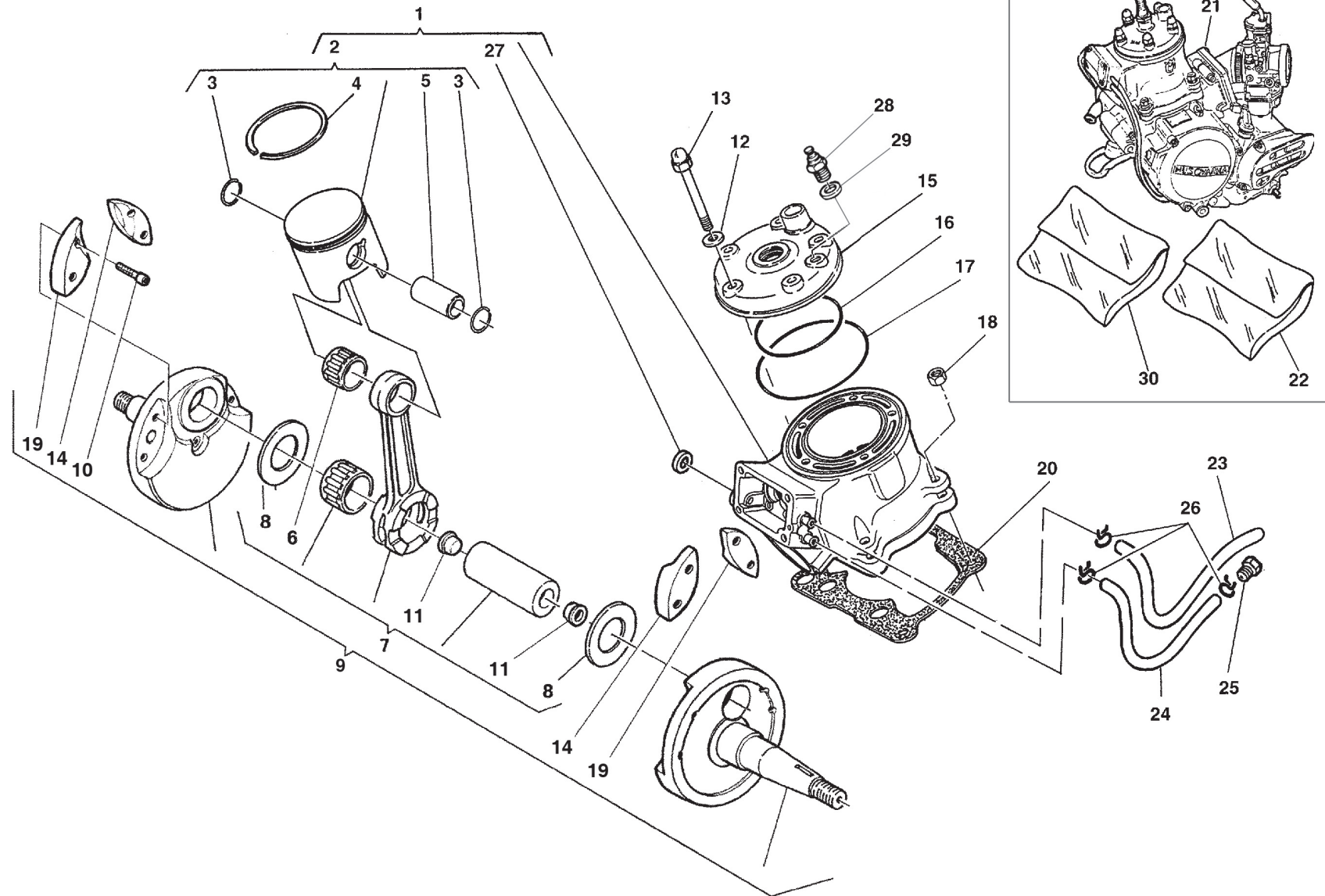

La sottoriportata tabella elenca i possibili accoppiamenti che consentono di ottenere il corretto gioco radiale di 0,002±0,010 mm

The table hereunder shows the possible coupling which allow to obtain a radial clearance of 0,002±0,010 mm

Le tableau ci-dessous indique tous les couplages possibles permettant d'obtenir le jeu radial exact de 0,002±0,010 mm

Die folgende Tabelle gibt die möglichen Verbindungen an für das genaue Radialspiel von 0,002±0,010 mm

La tabla que se da a continuación lista los acoplamientos posibles que permiten obtener el juego radial correcto de 0,002±0,010 mm

C: colore di selezione biella

C: rod selection colour

C: couleur de sélection bielle

C: Wahlfarbe der Pleuelstange

C: color de selección biela

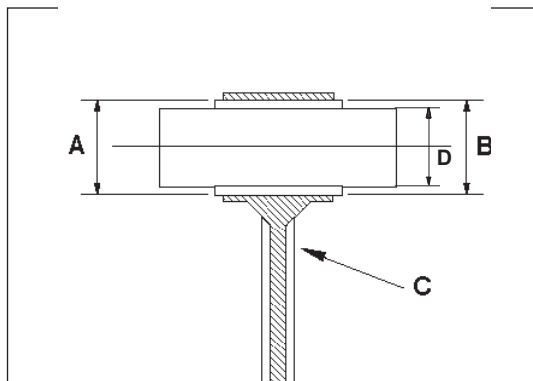

Colore di selezione foro «A» piede di biella (mm) Hole selection colour «A» connecting rod small end (mm) Couleur de sélection trou «A» pied de bielle (mm) Wahlfarbe der Bohrung «A» Pleuelstangenkopf (mm) Color de selección «A» pie de biela (mm)	Selezione gabbia a rullini «B» Cage selection «B» Sélection cage à rouleaux «B» Wahlnadelkäfig «B» Selección jaula de agujas «B»	Colore di selezione diametro «D» spinotto (mm) Diameter selection colour «D» Gudgeon (mm) Couleur de sélection diamètre «D» axe (mm) Wahlfarbe der Durchmesser «D» Bolzen (mm) Color de selección diámetro «D» perno (mm)
Rosso - Red - Rouge - Rot - Rojo 19,002±19,004	0 ÷ -2	Nero - Black - Noir - Schwarz - Negro 15,000±14,998
Bianco - White - Blanc - Weiss - Blanco 18,998 ÷ 19,000	-1 ÷ -3	Bianco - White - Blanc - Weiss - Blanco 14,998±14,996
Nero - Black - Noir - Schwarz - Negro 19,000±19,002	0 ÷ -2	Bianco - White - Blanc - Weiss - Blanc 14,998±14,996
Nero - Black - Noir - Schwarz - Negro 19,000±19,002	-1 ÷ -3	Nero - Black - Noir - Schwarz - Negro 15,000±14,998

Qualora, in sede di revisione del motore, si dovesse riscontrare un gioco radiale superiore al limite ammesso di 0,015 mm e non fosse più visibile il contrassegno del colore sullo stelo della biella, rilevare il diametro «A» del piede di biella e, in base a questo, montare la gabbietta appropriata.

When overhauling, should a radial clearance greater than the consented limit of 0.015 mm be noticed and the colour mark under the connecting rod small end is no more visible, collect the connecting rod small end «A» diameter and assemble the right cage according to it.

Si en révisonnant le moteur on trouve un jeu radial supérieur à la limite admise de 0,015 mm et le marque de la couleur n'est plus visible sur la tige de bielle, enregistrer le diamètre «A» du pied de bielle et assembler la cage exacte selon ce diamètre.

Falls bei Motorprüfung das Radialspiel über das zugelassene Mass von 0,015 mm sein sollte und das Farbkennzeichen an der Pleuelstange nicht mehr sichtbar ist, wird der «A»-Durchmesser des Pleuelstangenkopfes gemessen und aufgrund dessen der geeignete Käfig montiert.

En el caso que, cuando inspeccione el motor, encuentre un juego radial superior al límite admitido de 0,015 mm y no resultara más visible la señalización del color en el vástago de la biela, registre el diámetro «A» del piede biela y, sobre la base de este dato, monte la jaula adecuada.

NOTA: Nel richiedere la gabbia a rullini, specificare la selezione.

NOTE: When requesting the cage, specify the selection.

NOTA: En demandant la cage à rouleaux, spécifier la sélection.

BEMERKUNG: Bei Anfrage den genauen Wahlnadelkäfig angeben.

NOTA: cuando pida la jaula de agujas, especifique la selección.

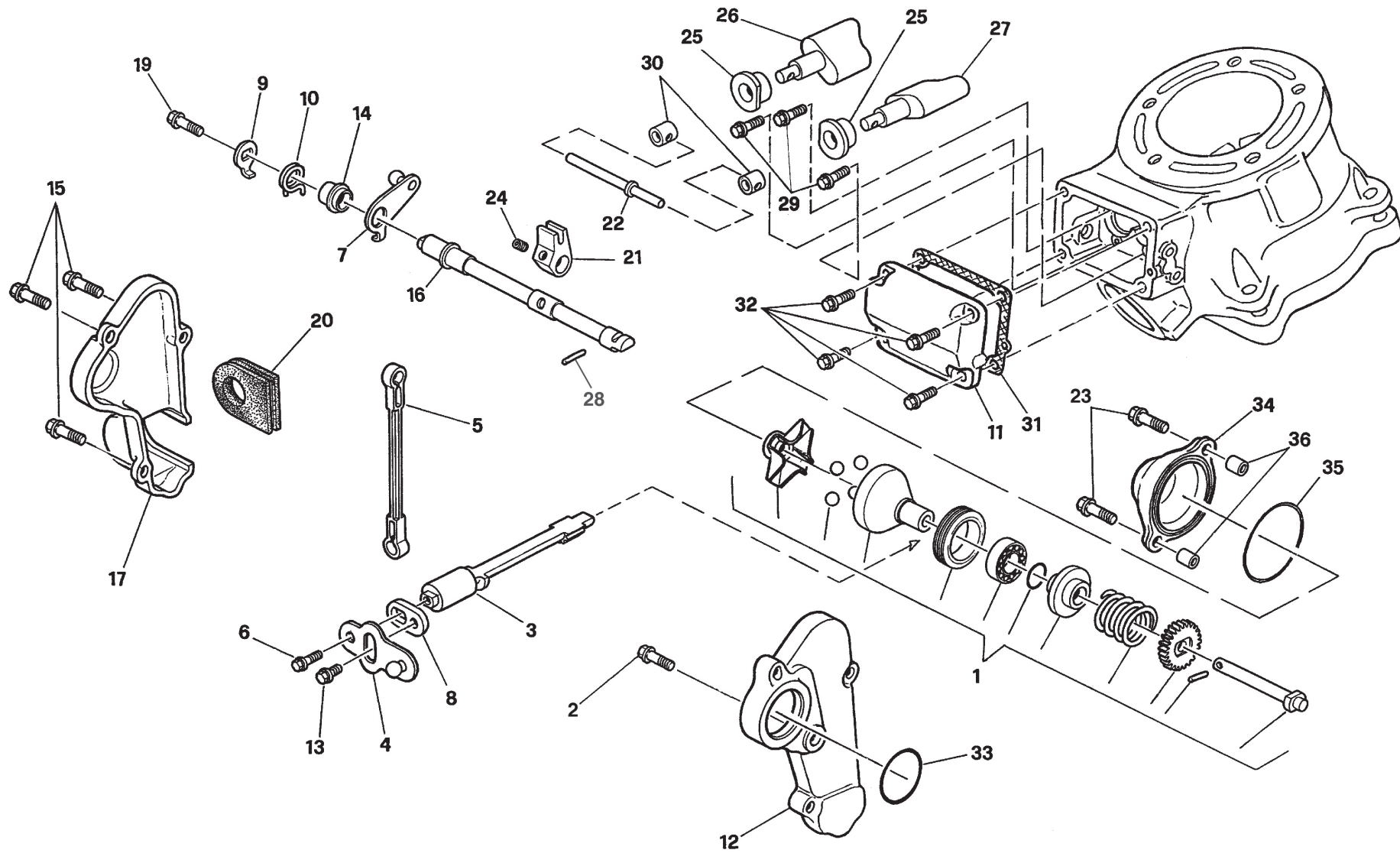

Note Notes Marke Notas	Pos. No. N. Index Pos.	N. Cod. Code No. Nr. Code Code Nr N. Cod.	Q.tà Q.ty Q.te M.ge C.ad	DENOMINAZIONE	NAME	DESIGNATION	BESHREIBUNG	DENOMINACION	Validità Validity Validité Gültig Validez
	1	8000 H0938	1	Assieme regolatore centrifugo	Regulator assy	Reglage	Regler	Regulador	
	2	Z000 67997	1	Vite (M5x12 mm)	Screw (M5x12 mm)	Vis (M5x12 mm)	Schraube (M5x12 mm)	Tornillo (M5x12 mm)	
	3	8000 83107	1	Alberino	Shhaft	Arbre	Welle	Eje	
	4	8B00 57022	1	Assieme leva registro rinvio	Lever	Levier	Hebel	Palanca	
	5	8000 83115	1	Astina	Brake	Tige	Stange	Varilla	
	6	Z000 67997	1	Vite (M5x12 mm)	Screw (M5x12 mm)	Vis (M5x12 mm)	Schraube (M5x12 mm)	Tornillo (M5x12 mm)	
	7	8000 83111	1	Assieme leva	Lever	Levier	Hebel	Palanca	
	8	8A00 57024	1	Leva rinvio	Lever	Levier	Hbel	Palanca	
	9	8000 83110	1	Leva	Lever	Levier	Hbel	Palanca	
	10	8000 83109	1	Molla	Spring	Ressort	Feder	Resorte	
	11	8000 83090	1	Coperchio	Cover	Couvercle	Deckel	Tapa	
	12	80A0 H0167	1	Basetta	Side	Base	Platte	Placa	
	13	ZF00 67997	1	Vite (M5x6,5 mm)	Screw (M5x6,5 mm)	Vis (M5x6,5 mm)	Schraube (M5x6,5 mm)	Tornillo (M5x6,5 mm)	
	14	8000 83114	1	Mozzo	Hub	Moyeau	Radnabe	Cubo	
	15	ZA00 67997	3	Vite (M5x16 mm)	Screw (M5x16 mm)	Vis (M5x16 mm)	Schraube (M5x16 mm)	Tornillo (M5x16 mm)	
	16	8000 83116	1	Albero comando valvole	Valve shaft	Arbre de comande soupape	Ventilwelle	Eje mando valvula	
	17	80A0 H0168	1	Coperchio	Cover	Couvercle	Deckel	Tapa	
	19	8000 67997	1	Vite (M5x12 mm)	Screw (M5x12 mm)	Vis (M5x12 mm)	Schraube (M5x12 mm)	Tornillo (M5x12 mm)	
	20	8000 83092	1	Guarnizione	Gasket	Guarniture	Dichtung	Junta	
	21	8000 83119	1	Biscottino leva	Lever	Levier	Hbel	Palanca	
	22	8000 83113	1	Perno di trascinamento	Pin	Pivot	Bolzen	Perno	
	23	Z000 62729	2	Vite (M6x25 mm)	Screw (M6x25 mm)	Vis (M6x25 mm)	Schraube (M6x25 mm)	Tornillo (M6x25 mm)	
	24	8000 83121	1	Grano	Dowel	Grain	Stift	Pasadòr	
	25	8000 83118	2	Bussola ritegno valvole	Valve retaining bush	Douille	Buchse	Manguito	
	26	8000 A3555	1	Valvola di scarico Dx	R.H. exhaust valve	Soupape d'echappement D.	Auslassventil R.	Valvula de escape der.	
	27	8000 A3556	1	Valvola di scarico Sx	L.H. exhaust valve	Soupape d'echappement G.	Auslassventil L.	Valvula de escape iz.	
	28	8000 47773	1	Rullino per valvola	Needle	Aiguille	Rolle	Rodillo	
	29	ZE00 67997	3	Vite (M5x10 mm)	Screw (M5x10 mm)	Vis (M5x10 mm)	Schraube (M5x10 mm)	Tornillo (M5x10 mm)	
	30	8000 A3557	2	Fermo corsa	Retainer	Arret	Klammer	Abrazaderza	
	31	8000 83049	1	Guarnizione	Gasket	Guarniture	Dichtung	Junta	
	32	ZA00 67997	4	Vite (M5x16 mm)	Screw (M5x16 mm)	Vis (M5x16 mm)	Schraube (M5x16 mm)	Tornillo (M5x16 mm)	
	33	8000 19789	1	Anello "OR"	"O"ring	Bague OR	"O"Ring	Anillo OR	
	34	80B0 83076	1	Coperchio regolatore	Cover	Couvercle	Deckel	Tapa	

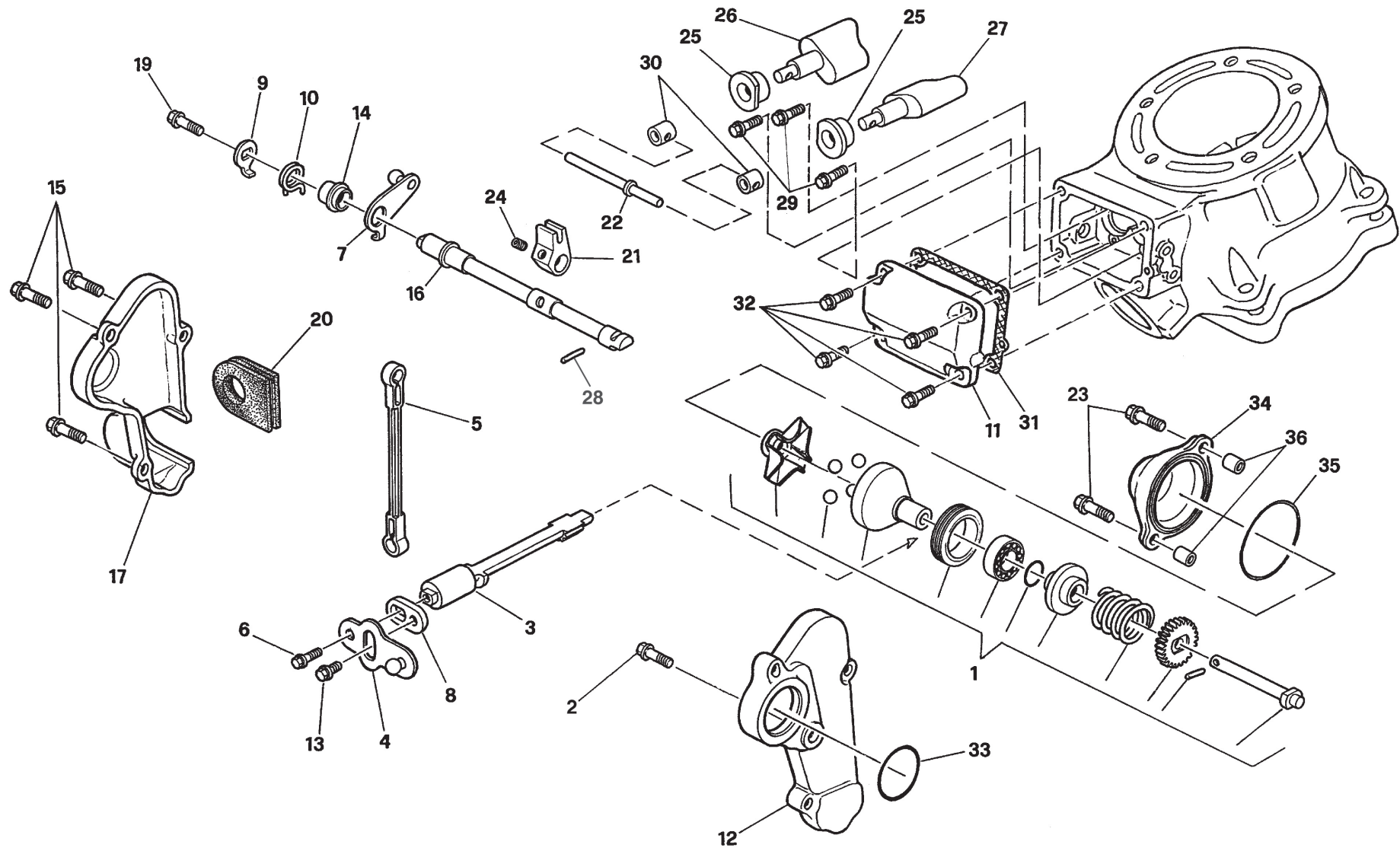

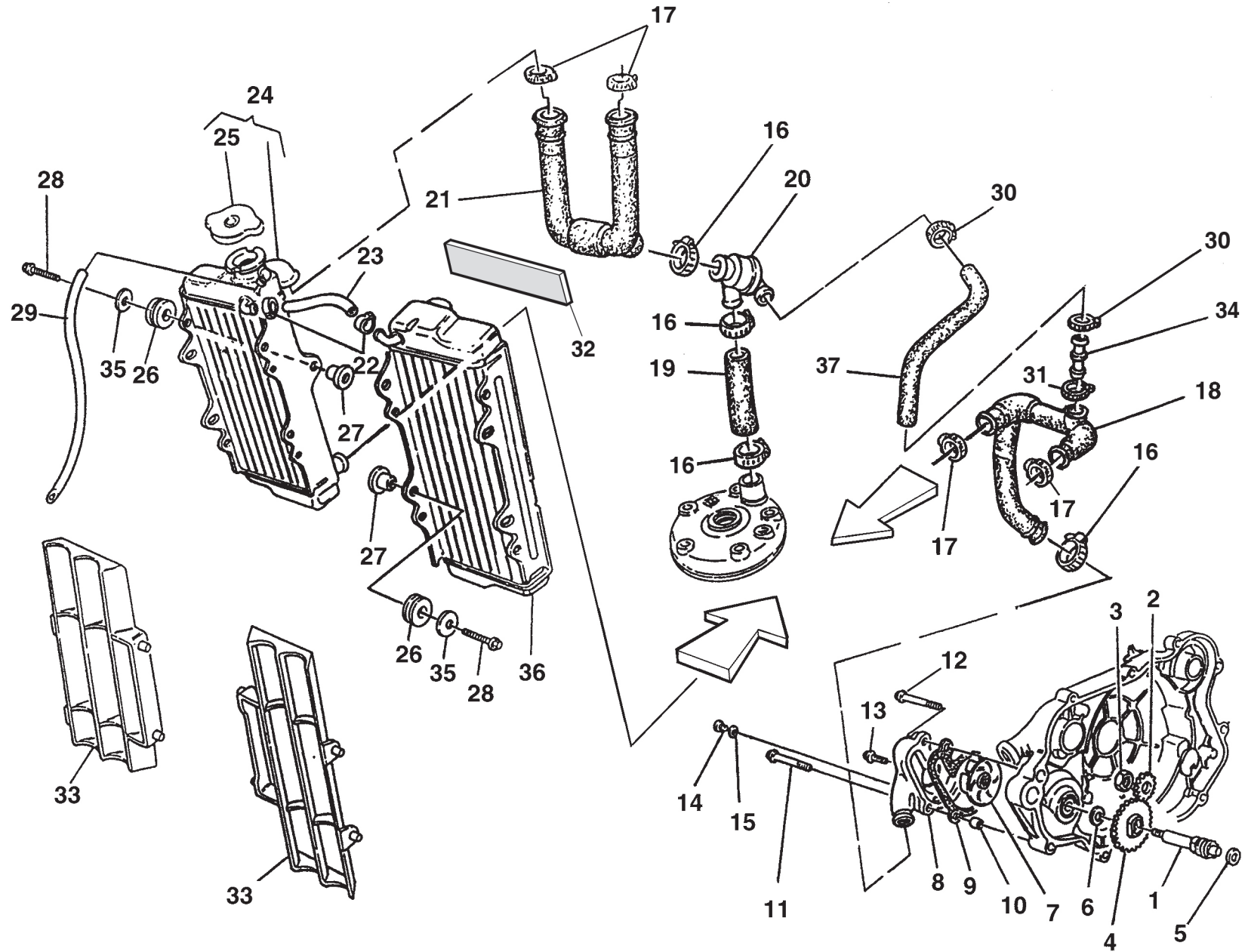



Note Notes Notes Marke Notas	Pos. No. N. Index Pos.	N. Cod. Code No. Nr. Code Code Nr N. Cod.	Q.tà Q.ty Q.te M.ge C.ad	DENOMINAZIONE	NAME	DESIGNATION	BESHREIBUNG	DENOMINACION	Validità Validity Validité Gültig Validez
	1	8000 79561	1	Alber.com.pompa acqua	Shaft	Arbre	Welle	Eje	
	2	8000 65923	1	Pignone (Z16)	Pinion (Z16)	Pignon (Z16)	Ritzel (Z16)	Engranaje (Z16)	
	3	8A00 04883	1	Dado	Nut	Ecrou	Mutter	Tuerca	
	4	8000 65935	1	Ingranaggio pompa (Z32)	Pinion (Z32)	Pignon (Z32)	Ritzel (Z32)	Engranaje (Z32)	
	5	8E00 34292	1	Rosetta	Washer	Rondelle	Scheibe	Arandela	
	6	8F00 28960	1	Rosetta	Washer	Rondelle	Scheibe	Arandela	
	7	8000 68277	1	Girante	Rotor	Couronne	Laufrad	Rotor	
	8	80B0 83024	1	Corpo pompa	Pump body	Corps pompe	Pumpenkoper	Corpo bomba	
	9	8000 65922	1	Guarnizione	Gasket	Garniture	Dichtung	Junta	
	10	1617 95501	2	Bussola	Bushing	Douille	Buchse	Manguito	
	11	Z000 62731	1	Vite (M6x45 mm)	Screw (M6x45 mm)	Vis (M6x45 mm)	Schraube (M6x45 mm)	Tornilo (M6x45 mm)	
	12	ZB00 67545	1	Vite (M6x55 mm)	Screw (M6x55 mm)	Vis (M6x55 mm)	Schraube (M6x55 mm)	Tornilo (M6x55 mm)	
	13	Z000 62728	1	Vite (M6x20 mm)	Screw (M6x20 mm)	Vis (M6x20 mm)	Schraube (M6x20 mm)	Tornilo (M6x20 mm)	
	14	ZS00 67545	1	Vite (M6x8 mm)	Screw (M6x8 mm)	Vis (M6x8 mm)	Schraube (M6x8 mm)	Tornilo (M6x8 mm)	
	15	62ND 15673	1	Rosetta	Washer	Rondelle	Scheibe	Arandela	
	16	8000 H6508	4	Fascetta	Clamp	Collier	Schelle	Banda	
	17	8000 H6506	3	Fascetta	Clamp	Collier	Schelle	Banda	
	18	8000 H5730	1	Tubo radiatori pompa	Pipe	Tuyau	Rohr	Tubo	
	19	8000 H5366	1	Tubo testa-termostato	Pipe	Tuyau	Rohr	Tubo	
	20	8000 75984	1	Termostato	Thermo-switch	Thermostate	Thermostat	Termostato	
	21	8000 94681	1	Tubo termostato-radiatori	Pipe	Tuyau	Rohr	Tubo	
	22	8000 56462	2	Fascetta	Clamp	Collier	Schelle	Banda	
	23	8000 H5371	1	Tubo raccordo radiatori	Pipe	Tuyau	Rohr	Tubo	
	24	8000 92216	1	Radiatore destro (TOYO)	Right radiator (TOYO)	Radiateur droit (TOYO)	Rechter Kühler (TOYO)	Radiador derecho (TOYO)	
A	24	8000 A7970	1	Radiatore destro (KTM)	Right radiator (KTM)	Radiateur droit (KTM)	Rechter Kühler (KTM)	Radiador derecho (KTM)	
A	24	8000 A7974	1	Radiatore destro (ALEXON)	Right radiator (ALEXON)	Radiateur droit (ALEXON)	Rechter Kühler (ALEXON)	Radiador derecho (ALEXON)	
	25	8000 79077	1	Tappo radiatore (TOYO)	Plug (TOYO)	Bouchon (TOYO)	Verschluss (TOYO)	Tapón (TOYO)	
A	25	8000 A7972	1	Tappo radiatore (KTM)	Plug (KTM)	Bouchon (KTM)	Verschluss (KTM)	Tapón (KTM)	
A	25	8000 A7975	1	Tappo radiatore (ALEXON)	Plug (ALEXON)	Bouchon (ALEXON)	Verschluss (ALEXON)	Tapón (ALEXON)	
	26	8000 59803	6	Gommino	Rubber pad	Pièce caoutchouc	Gummistück	Junta de goma	
	27	8D00 59802	6	Bussola	Bushing	Douille	Buchse	Manguito	
	28	Z000 62729	6	Vite	Screw	Vis	Schraube	Tornilo	
	29	8B00 43715	1	Tubo sfiato	Pipe	Tuyau	Rohr	Tubo	

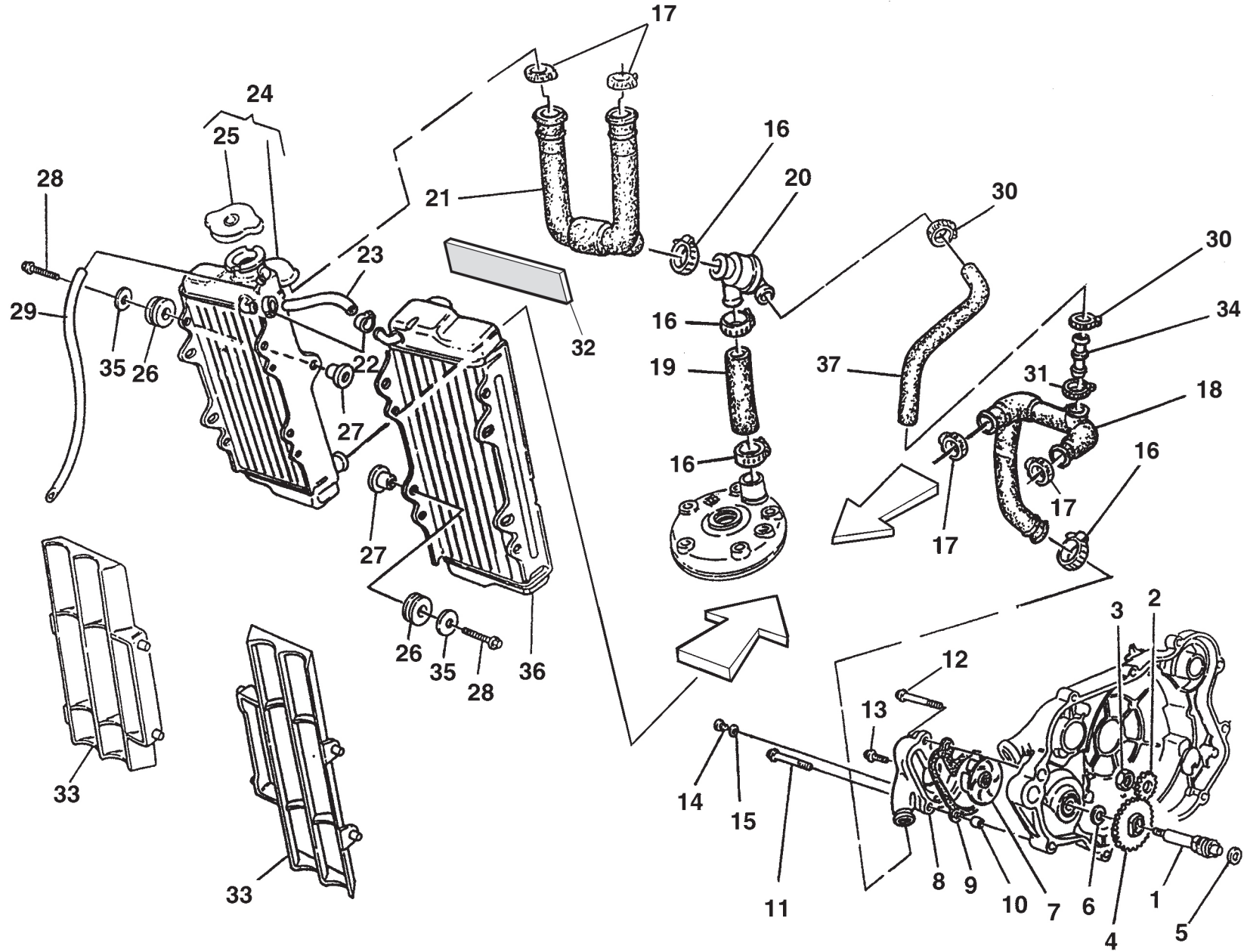

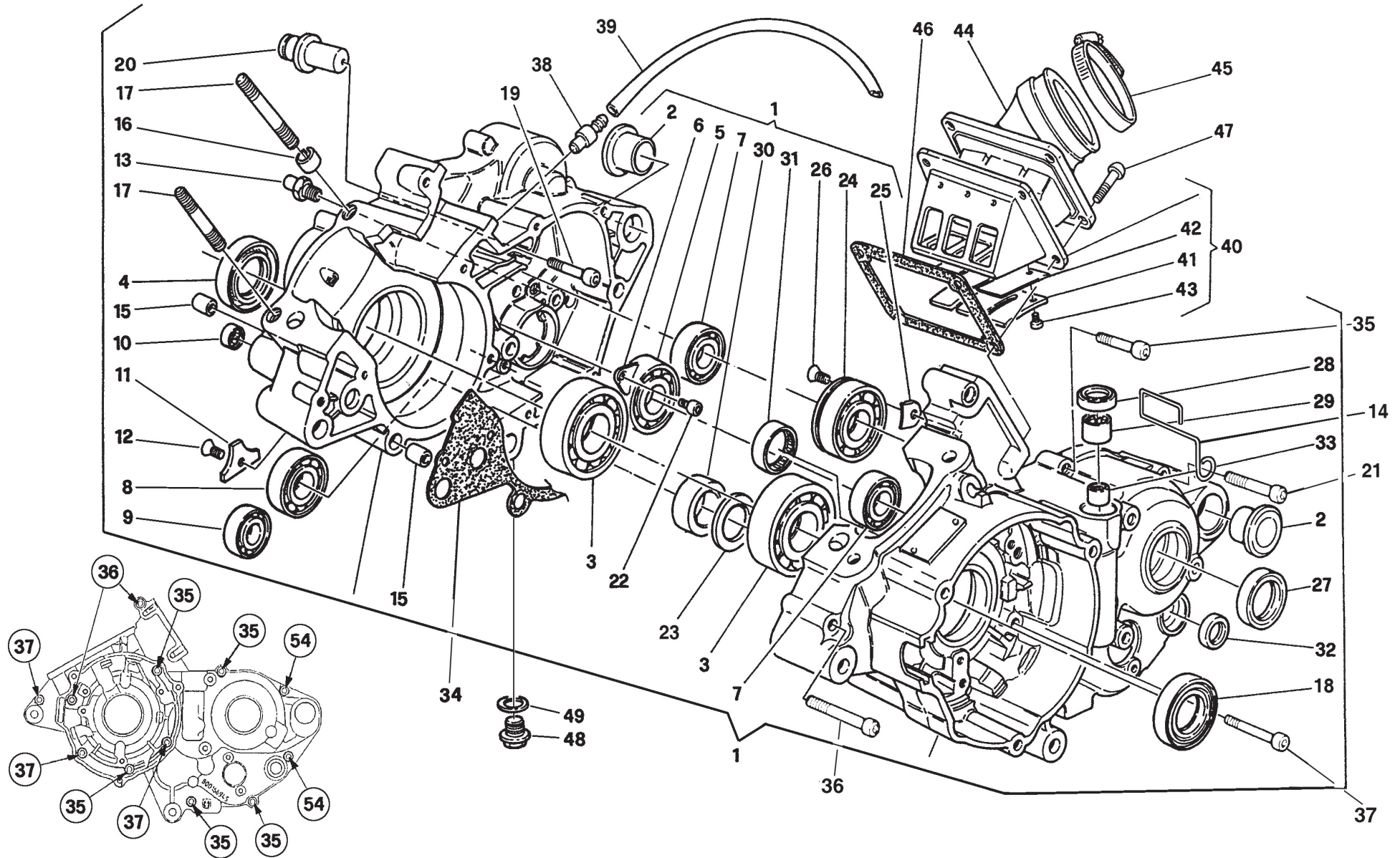

Note Notes Notes Marke Notas	Pos. No. N. Index Pos.	N. Cod. Code No. Nr. Code Code Nr N. Cod.	Q.tà Q.ty Q.te M.ge C.ad	DENOMINAZIONE	NAME	DESIGNATION	BESHREIBUNG	DENOMINACION	Validità Validity Validité Gültig Validez
	1	8000 H0464	1	Carter accoppiati compl.	Crankcase assy	Carters assemblé compl.	Kürbelgehäuse kpl.	Carter motor compl.	
	2	8A00 71154	2	Bussola	Bushing	Douille	Büshse	Manguito	
	3	8000 88828	2	Cuscinetto (ø22xø56x16 mm)	Ball bearing(ø22xø56x16mm)	Roulement (ø22xø56x16 mm)	Lager (ø22xø56x16 mm)	Cojienete (ø22xø56x16 mm)	
	4	8000 59977	1	Anello di tenuta	Seal ring	Bague d'étanchéité	Dichtungsring	Anillo de retención	
	5	8000 43382	1	Cuscinetto (ø17xø47x14 mm)	Bearing (ø17xø47x14 mm)	Roulement (ø17xø47x14 mm)	Lager (ø17xø47x14 mm)	Cojienete (ø17xø47x14 mm)	
	6	8000 53324	1	Piastrina	Plate	Plaquette	Plättchen	Placa	
	7	8000 21939	1	Cuscinetto (ø15xø35x11 mm)	Bearing (ø15xø35x11 mm)	Roulement (ø15xø35x11 mm)	Lager (ø15xø35x11 mm)	Cojienete (ø15xø35x11 mm)	
	8	8A00 53248	1	Cuscinetto (ø12xø32x10 mm)	Bearing (ø12xø32x10 mm)	Roulement (ø12xø32x10 mm)	Lager (ø12xø32x10 mm)	Cojienete (ø12xø32x10 mm)	
	9	8A00 54164	1	Cuscinetto	Bearing	Roulement	Lager	Cojienete	
	10	8000 47678	1	Cuscinetto a rullini	Needle bearing	Roulement à aiguilles	Nadelkafig	Cojienete	
	11	8000 66952	1	Piastrina	Plate	Plaquette	Plättchen	Placa	
	12	Z000 42643	1	Vite	Screw	Vis	Schraube	Tornillo	
	13	8A00 66953	1	Perno	Pin	Pivot	Bolzen	Perno	
	14	8000 78031	1	Anello guida tubi sfiato carbur.	Carburetor hoses ring	Bague tuyau carburateur	Vergaserrohrring	Anillo tubos carburador	
	15	8000 07719	4	Bussola	Bushing	Douille	Büshse	Manguito	
	16	8000 99767	2	Spina elastica	Pin	Goupille	Stift	Clavija	
	17	8000 74836	4	Prigioniero (M8 x 51 mm)	Stud bolt (M8 x 51 mm)	Prisonnier (M8 x 51 mm)	Stiftschraube (M8 x 51 mm)	Prisionero (M8 x 51 mm)	
	18	8000 92896	1	Anello di tenuta	Seal ring (ø20xø40x7 mm)	Bague d'étan.	Dichtungsring	Anillo de reten.	
	19	60ND 07335	1	Vite	Screw	Vis	Schraube	Tornillo	
	20	8000 77841	1	Perno	Pin	Pivot	Bolzen	Perno	
	21	60ND 02518	2	Vite (M6 x 65 mm)	Screw (M6 x 65 mm)	Vis (M6 x 65 mm)	Schraube (M6 x 65 mm)	Tornillo (M6 x 65 mm)	
	22	Z000 67997	1	Vite	Screw	Vis	Schraube	Tornillo	
	23	8E00 32069	1	Rosetta	Washer	Rondelle	Scheibe	Arandela	
	24	8000 51745	1	Cuscinetto (ø20xø52x15 mm)	Bearing (ø20xø52x15 mm)	Roulement (ø20xø52x15 mm)	Lager (ø20xø52x15 mm)	Cojienete (ø20xø52x15 mm)	
	25	8000 51746	1	Piastrina	Plate	Plaquette	Plättchen	Placa	
	26	8000 42643	3	Vite	Screw	Vis	Schraube	Tornillo	
	27	8000 36357	2	Anello di tenuta	Seal ring	Bague d'étanchéité	Dichtungsring	Anillo de retención	
	28	8000 48856	2	Anello di tenuta	Seal ring	Bague d'étanchéité	Dichtungsring	Anillo de retención	
	29	8000 49016	1	Boccola (ø13xø19x12 mm)	Bushing (ø13xø19x12 mm)	Douille (ø13xø19x12 mm)	Büchse (ø13xø19x12 mm)	Manguito (ø13xø19x12 mm)	
	30	8000 54427	1	Rullo di contrasto	Roller	Aiguille	Rolle	Rodillo	
	31	8000 62200	1	Cuscinetto a rullini (ø24xø30x7,5 mm)	Needle bearing (ø24xø30x7,5 mm)	Roulement à aiguilles (ø24xø30x7,5 mm)	Nadelkafig (ø24xø30x7,5 mm)	Cojienete (ø24xø30x7,5 mm)	
	32	8000 34451	1	Anello di tenuta	Seal ring	Bague d'étanchéité	Dichtungsring	Anillo de retención	

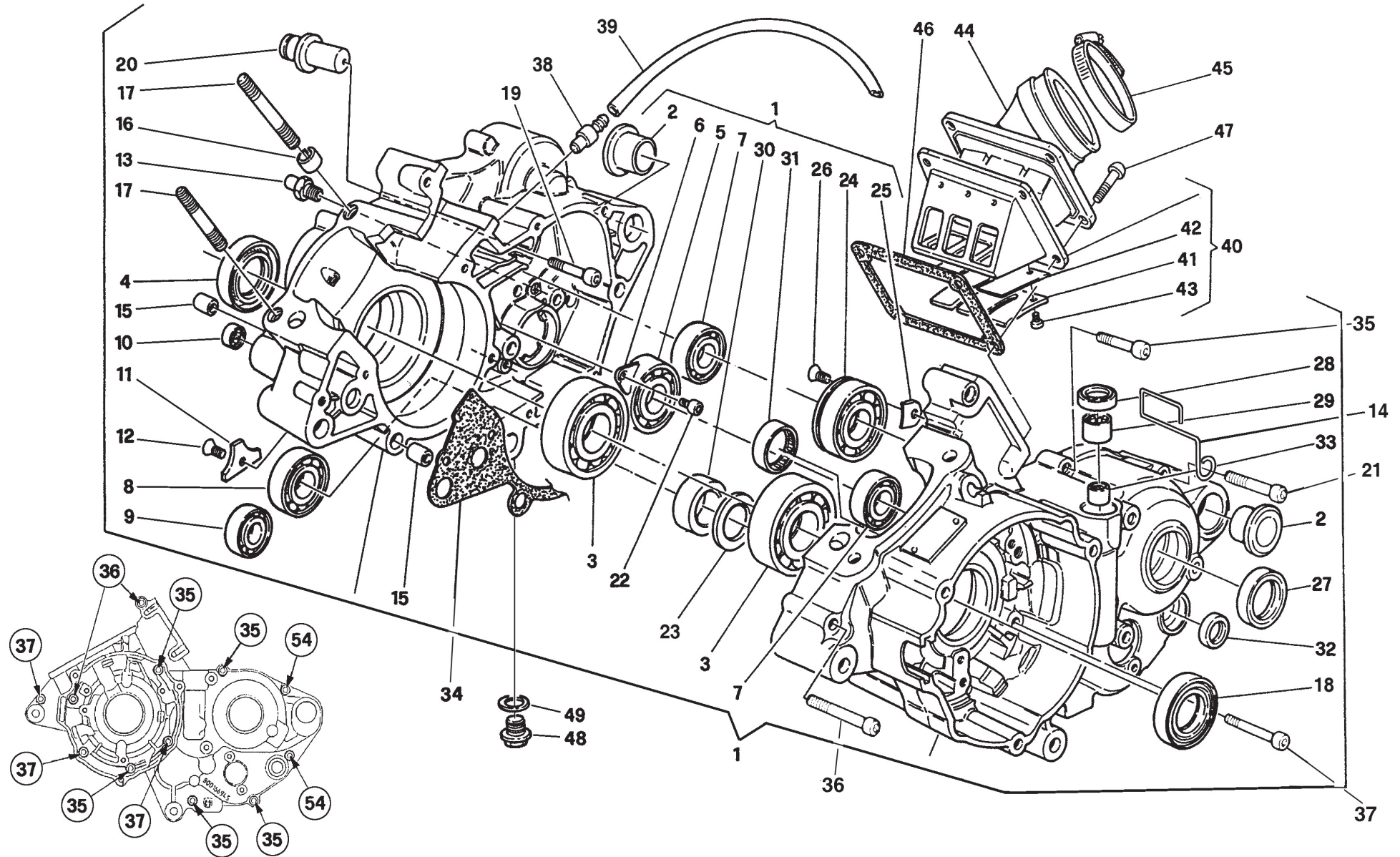

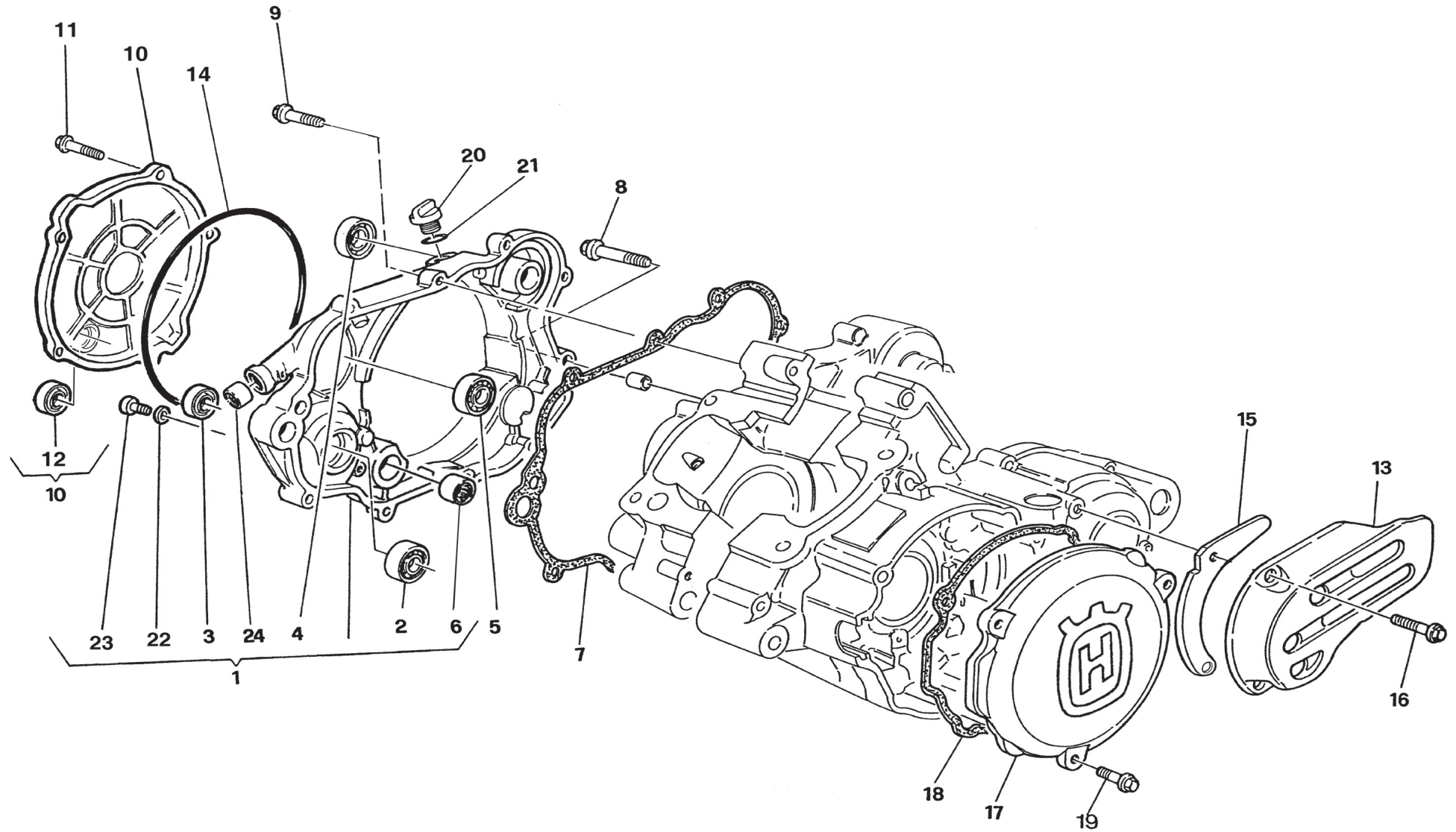

Note Notes Marke Notas	Pos. No. N. Index Pos.	N. Cod. Code No. Nr. Code Code Nr N. Cod.	Q.tà Q.ty Q.te M.ge C.ad	DENOMINAZIONE	NAME	DESIGNATION	BESHREIBUNG	DENOMINACION	Validità Validity Validité Gültig Validez
	1	8A00 H0428	1	Coperchio carter DX	R. H. crankcase cover	Couvercle carter D.	Deckel R. carter	Juego tapa carter lz.	
	2	8000 28959	2	Cuscinetto (ø10xØ26x8 mm)	Bearing (ø10xØ26x8 mm)	Roulement (ø10xØ26x8 mm)	Llager (ø10xØ26x8 mm)	Cojinete (ø10xØ26x8 mm)	
	3	8000 68278	1	Anello (ø8,6xØ18x8mm)	Ring (ø8,6xØ18x8 mm)	Bague (ø8,6xØ18x8 mm)	Ring (ø8,6xØ18x8 mm)	Ring (ø8,6xØ18x8 mm)	
	4	8000 36653	1	Anello (ø16xØ25x4 mm)	Ring (ø16xØ25x4 mm)	Bague (ø16xØ25x4 mm)	Ring (ø16xØ25x4 mm)	Ring (ø16xØ25x4 mm)	
	5	8000 06597	1	Cuscinetto (ø8xØ22x7 mm)	Bearing (ø8xØ22x7 mm)	Roulement (ø8xØ22x7 mm)	Llager (ø8xØ22x7 mm)	Cojinete (ø8xØ22x7 mm)	
	6	8000 53322	1	Cuscinetto (ø12xØ19x12 mm)	Bearing (ø12xØ19x12 mm)	Roulement (ø12xØ19x12 mm)	Llager (ø12xØ19x12 mm)	Cojinete (ø12xØ19x12 mm)	
	7	8000 66968	1	Guarnizione	Gasket	Garnitue	Dichtung	Junta	
	8	ZA00 67545	2	Vite (M6x35 mm)	Screw (M6x35 mm)	Vis (M6x35 mm)	Schraube (M6x35 mm)	Tornillo (M6x35 mm)	
	9	Z000 62729	6	Vite (M6x25 mm)	Screw (M6x25 mm)	Vis (M6x25 mm)	Schraube (M6x25 mm)	Tornillo (M6x25 mm)	
	10	80C0 H1411	1	Coperchio frizione completo	Clutch cover assy.	Couvercle embrayage compl.	Kupplungsdeckel Kpl.	Tapa embrague compl.	
	11	Z000 62729	5	Vite (M6x25 mm)	Screw (M6x25 mm)	Vis (M6x25 mm)	Schraube (M6x25 mm)	Tornillo (M6x25 mm)	
	12	8000 53340	1	Oblò	Inspection plug	Capuchon de inspection	Stopfen	Portilla	
	13	8000 66973	1	Coperchio pignone	Cover	Couvercle	Deckel	Tapa accion. embrague	
	14	8000 H1285	1	Anello OR	O Ring	Bague OR	Ring OR	Anillo OR	
	15	8000 74758	1	Piastrina	Plate	Plaque	Platte	Placa	
	16	Z000 62727	2	Vite (M6x16 mm)	Screw (M6x16 mm)	Vis (M6x16 mm)	Schraube (M6x16 mm)	Tornillo (M6x16 mm)	
	17	8AC0 66947	1	Coperchio volano	Cover	Couvercle	Deckel	Tapa accion. embrague	
	18	8000 66972	1	Guarnizione	Gasket	Garnitue	Dichtung	Junta	
	19	Z000 62728	3	Vite (M6x20 mm)	Screw (M6x20 mm)	Vis (M6x20 mm)	Schraube (M6x20 mm)	Tornillo (M6x20 mm)	
	20	8000 36786	1	Tappo per carico olio	Plug	Bouchon	Verschluss	Tapón intruduecion aceite	
	21	8000 27960	1	Rosetta	Washer	Rondelle	Scheibe	Arandela	
	22	8000 03271	1	Guarnizione	Gasket	Garnitue	Dichtung	Junta	
	23	8S00 67545	1	Vite	Screw	Vis	Schraube	Tornillo	
	24	8000 48856	1	Anello (ø13xØ20x4 mm)	Ring (ø13xØ20x4 mm)	Bague (ø13xØ20x4 mm)	Ring (ø13xØ20x4 mm)	Ring (ø13xØ20x4 mm)	

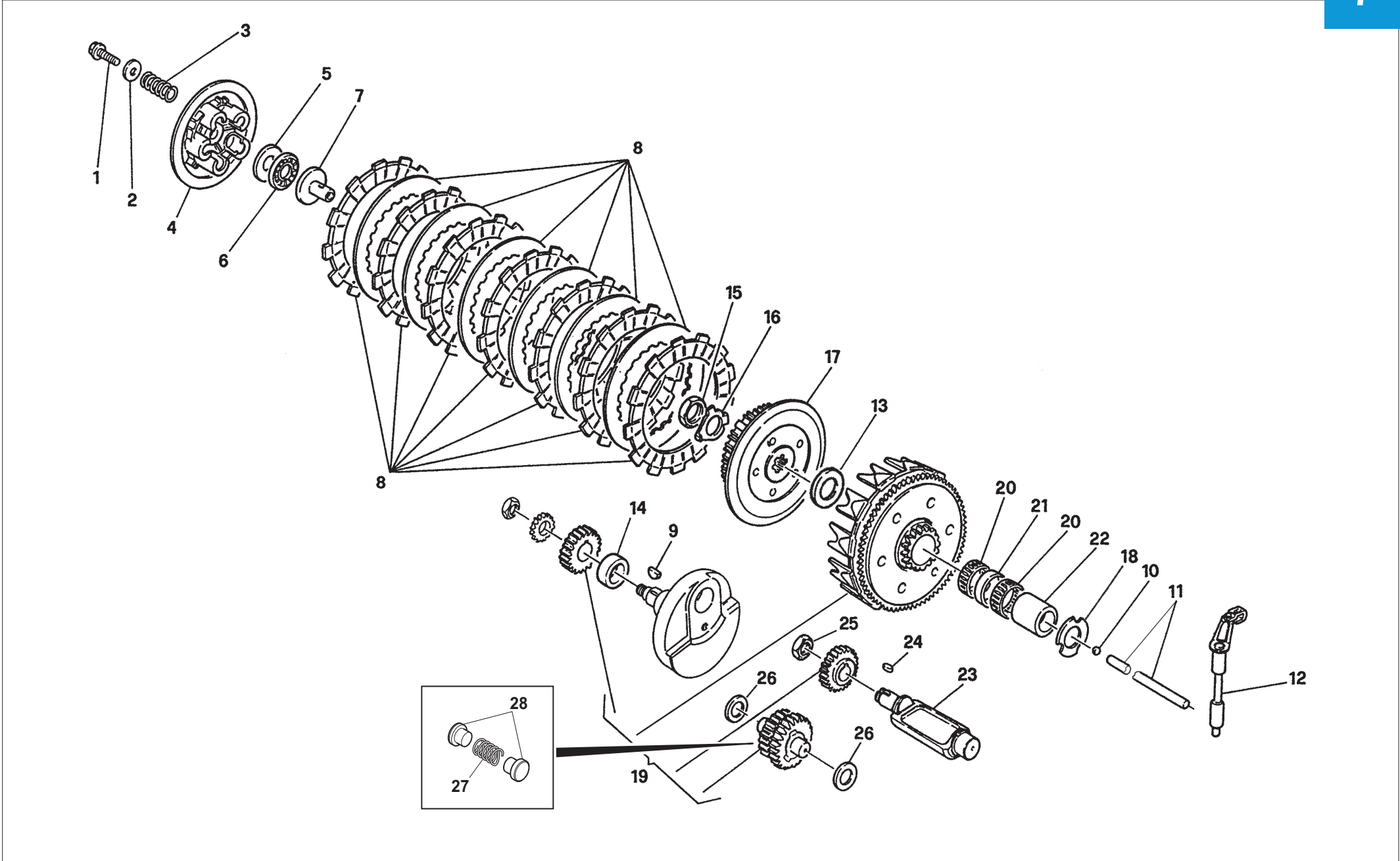



Note Notes Marke Notas	Pos. No. N. Index Pos.	N. Cod. Code No. Nr. Code Code Nr N. Cod.	Q.tà Q.ty Q.te M.ge C.ad	DENOMINAZIONE	NAME	DESIGNATION	BESHREIBUNG	DENOMINACION	Validità Validity Validité Gültig Validez
	1	Z000 62728	5	Vite	Screw	Vis	Schraube	Tornillo	
	2	Z000 48814	5	Rosetta	Washer	Rondelle	Scheibe	Arandela	
	3	8000 83085	5	Molla	Spring	Ressort	Feder	Resorte	
	4	8000 70467	1	Spingidisco	Pressure plate	Pousse disque	Scheibendrucker	Empuia disco	
	5	8000 70551	1	Ralla	Washer	Rondelle	Scheibe	Arandela	
	6	8000 70550	1	Cuscinetto a rullini	Needle bearing	Roulement à aiguilles	Nadelkäfig	Cojinete	
	7	8000 70549	1	Piattello	Disc	Disque	Scheibe	Disco	
	8	8000 88822	1	Ass. gruppo frizione	Clutch group assy	Groupe embrayage compl.	Kupplungsgruppe Kpl.	Grupo embrague compl.	
	9	8000 54507	1	Linguetta a disco	Key	Clavette	Keil	Lengüeta americana	
	10	6BN0 21506	1	Sfera	Ball	Bille	Kugel	Esfera	
	11	8000 H4192	1	Astina	Rod	Tige	Stange	Varilla	
	12	8000 70552	1	Albero comando frizione	Shaft	Arbre	Welle	Eje	
	13	8000 H4193	1	Rosetta	Washer	Rondelle	Scheibe	Arandela	
	14	8000 92820	1	Distanziale	Spacer	Entretoise	Distanzstück	Separador	
	15	8A00 31386	1	Dado	Nut	Ecrou	Mutter	Tuerca	
	16	8000 29089	1	Rosetta di sicurezza	Washer	Rondelle	Scheibe	Arandela	
	17	8000 70468	1	Mozzo portadischi	Clutch hub	Moyeu porte disque	Scheibenthalernabe	Porta discos	
	18	8000 46428	1	Rosetta	Washer	Rondelle	Scheibe	Arandela	
	19	8000 H5728	1	Coppia ingranaggi primaria (Z 22/72)	Set of matched primary (Z 22/72)	Engrenages primarie (Z 22/72)	Stirnraderpaar(Z 22/72)	Copla engranaje transmisiòn primaria (Z 22/72)	
	20	8A00 25044	2	Cuscinetto a rullini	Needle bearing	Roulement à aiguilles	Nadelkäfig	Cojinete	
	21	8A00 36849	1	Distanziale	Spacer	Entretoise	Distanzstück	Separador	
	22	8A00 65845	1	Distanziale	Spacer	Entretoise	Distanzstück	Separador	
	23	8000 66954	1	Contralbero d'equilibrio	Layshhaft	Arbre de bal.	Worgelegewelle	Conta eje	
	24	8000 38707	1	Linguetta	Key	Clavette	Keil	Lengüeta americana	
	25	80A0 47665	1	Dado	Nut	Ecrou	Mutter	Tuerca	
	26	8000 04551	2	Rosetta di rasamento (0,3 mm)	Washer (0,3 mm)	Rondelle (0,3 mm)	Scheibe (0,3 mm)	Arandela (0,3 mm)	
	26	8C00 04551	2	Rosetta di rasamento (0,6 mm)	Washer (0,6 mm)	Rondelle (0,6 mm)	Scheibe (0,6 mm)	Arandela (0,6 mm)	
	26	8E00 04551	2	Rosetta di rasamento (0,8 mm)	Washer (0,8 mm)	Rondelle (0,8 mm)	Scheibe (0,8 mm)	Arandela (0,8 mm)	
	26	8G00 04551	2	Rosetta di rasamento (1,0 mm)	Washer (1,0 mm)	Rondelle (1,0 mm)	Scheibe (1,0 mm)	Arandela (1,0 mm)	
	27	8000 A1406	1	Molla	Spring	Ressort	Feder	Resorte	
	28	8000 55588	2	Perno	Pin	Pivot	Stift	Perno	

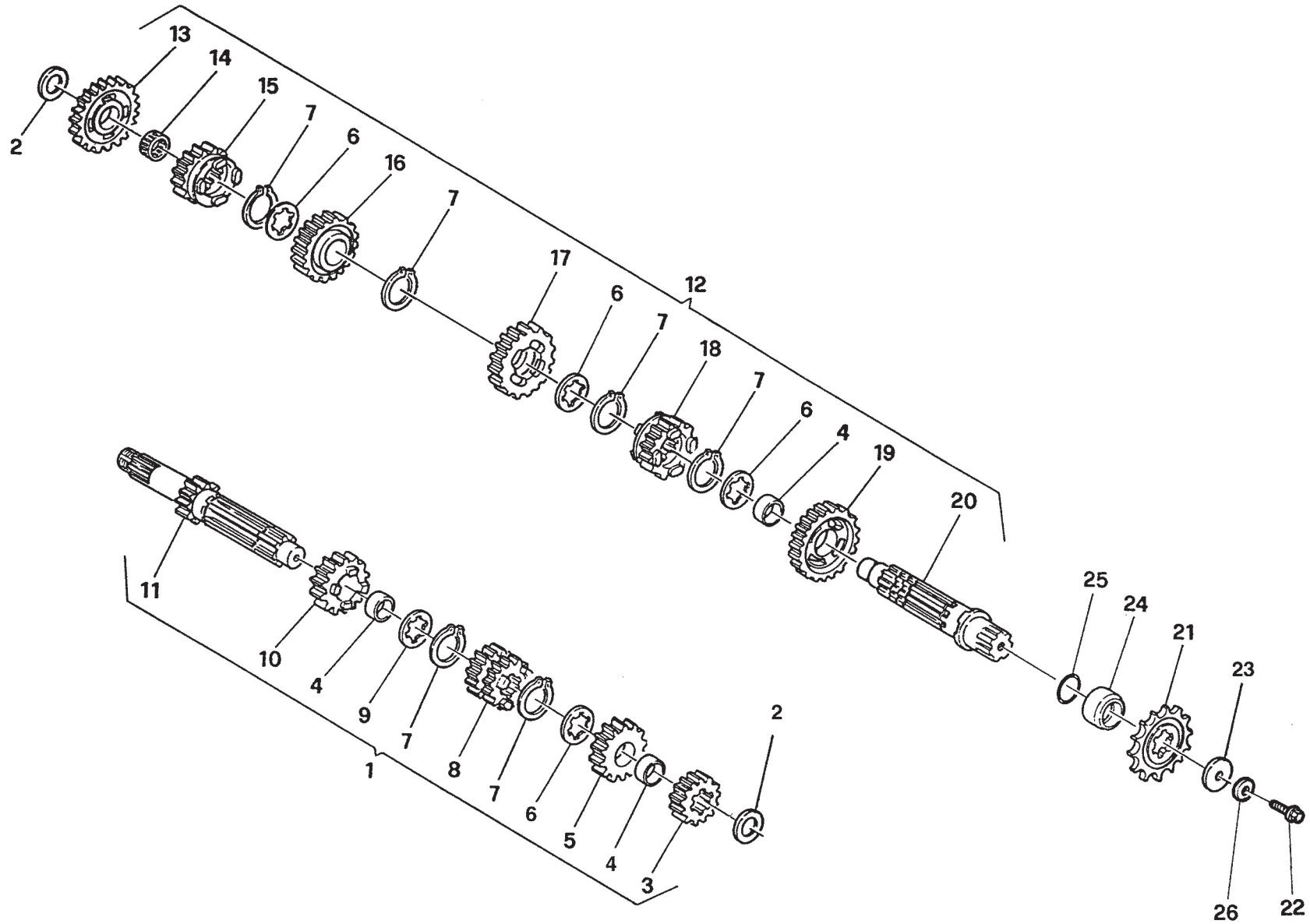



Note Notes Notas	Pos. No. Index Pos.	N. Cod. Code No. Nr. Code Code Nr N. Cod.	Q.tà Q.ty Q.te M.ge C.ad	DENOMINAZIONE	NAME	DESIGNATION	BESHREIBUNG	DENOMINACION	Validità Validity Validité Gültig Validez
	1	8000 75962	1	Assieme albero primario	Main shaft compl.	Arbre primaire compl.	Hauptwelle, Kpl.	Eje primario comp.	
	2	8000 68860	2	Rosetta di rasamento (0,3 mm)	Washer (0,3 mm)	Rondelle (0,3 mm)	Scheibe (0,3 mm)	Arandela (0,3 mm)	
	2	8B00 68860	2	Rosetta di rasamento (0,5 mm)	Washer (0,5 mm)	Rondelle (0,5 mm)	Scheibe (0,5 mm)	Arandela (0,5 mm)	
	2	8C00 68860	2	Rosetta di rasamento (0,6 mm)	Washer (0,6 mm)	Rondelle (0,6 mm)	Scheibe (0,6 mm)	Arandela (0,6 mm)	
	2	8D00 68860	2	Rosetta di rasamento (0,8 mm)	Washer (0,8 mm)	Rondelle (0,8 mm)	Scheibe (0,8 mm)	Arandela (0,8 mm)	
	2	8E00 68860	2	Rosetta di rasamento (1,0 mm)	Washer (1,0 mm)	Rondelle (1,0 mm)	Scheibe (1,0 mm)	Arandela (1,0 mm)	
	2	8F00 68860	2	Rosetta di rasamento (1,2 mm)	Washer (1,2 mm)	Rondelle (1,2 mm)	Scheibe (1,2 mm)	Arandela (1,2 mm)	
	3	8000 75967	1	Ingr. seconda vel. A. P. (Z15)	2nd gear, counter shaft (Z15)	Engrenage 2ème A.P. (Z15)	Zahnrad 2 (Z15)	Engr. 2° velocidad (Z15)	
	4	8A00 61261	3	Bussola	Bush	Douille	Buchse	Casquillo	
	5	8000 75966	1	Ingr. sesta vel A. P. (Z23)	6th gear, main shaft (Z23)	Pignon 6ème A.P. (Z23)	Zahnrad 6 A.W. (Z23)	Engranaje 6° velocidad (Z23)	
	6	8000 72800	3	Rosetta	Washer	Rondelle	Scheibe	Arandela	
	7	8000 31768	6	Anello elastico	Split ring	Anneau ressort	Sprengring	Anillo elástico	
	8	8000 75965	1	Ingr. A.P. 3ª e 4ª (Z18/20)	3rd and 4 th gears, main shaft (Z18/20)	Engrenage 3ème et 4 éme (Z18/20)	Zahnrad A.W. 3 u. 4.Gang (Z18/20)	Engr. 3° y 4° velocidad (Z18/20)	
	9	8000 36023	1	Rosetta	Washer	Rondelle	Scheibe	Arandela	
	10	8000 75964	1	Ingr. quinta vel. A. P. (Z22)	5th gear, main shaft (Z22)	Pignon A.P. 5ème (Z22)	Zahnrad 5 A.W. (Z22)	Engranaje 5° velocidad (Z22)	
	11	8000 75963	1	Albero primario (Z13)	Main shaft (Z13)	Arbre primaire (Z13)	Hauptwelle (Z13)	Eje primario (Z13)	
	12	8000 75968	1	Assieme albero secondario	Layshaft compl.	Arbre secondaire compl.	Vorgelegewelle, Kpl.	Eje secundario comp.	
	13	8000 75975	1	Ingr. prima vel. A. S. (Z35)	1st gear, counter shaft (Z35)	Pignon 1ère A.S. (Z35)	Zahnrad 1 N.W. (Z35)	Engr. 1° velocidad (Z35)	
	14	8000 40449	1	Cuscinetto a rullini (ø16xø20x10 mm)	Needle bearing (ø16xø20x10 mm)	Roulement à aiguilles (ø16xø20x10 mm)	Nadelkäfig (ø16xø20x10 mm)	Cojinete (ø16xø20x10 mm)	
	15	8000 75974	1	Ingr. quinta vel. A. S. (Z21)	5th gear, counter shaft (Z21)	Pignon 5ème A.S. (Z21)	Zahnrad 5 N.W. (Z21)	Engr. 5° velocidad (Z21)	
	16	8000 75973	1	Ingr. quarta vel. A. S. (Z22)	4th gear, counter shaft (Z22)	Engrenage 4ème A.S. (Z22)	Zahnrad 4 N.W. (Z22)	Engr. 4° velocidad (Z22)	
	17	8000 75972	1	Ingran. terza vel. A. S. (Z24)	3rd gear, counter shaft (Z24)	Pignon 3ème A.S. (Z24)	Zahnrad 3 N.W. (Z24)	Engr. 3° velocidad (Z24)	
	18	8000 75971	1	Ingr. sesta vel. A. S. (Z20)	6th gear, counter shaft (Z20)	Pignon 6ème A.S. (Z20)	Zahnrad 6 N.W. (Z20)	Engr. 6° velocidad (Z20)	
	19	8000 75970	1	Ingran. sec. vel. A. S. (Z27)	2nd gear, counter shaft (Z27)	Pignon 2ème A.S. (Z27)	Zahnrad 2 N.W. (Z27)	Engr. 2° velocidad (Z27)	
	20	8000 75969	1	Albero secondario	Layshaft	Arbre secondaire	Vorgelegewelle	Eje secundario	
W	21	8A00 65955	1	Pignone uscita cambio (Z13)	Pinion (Z13)	Pignon (Z13)	Ritzel (Z13)	Piñón (Z13)	
M	21	8B00 65955	1	Pignone uscita cambio (Z14)	Pinion (Z14)	Pignon (Z14)	Ritzel (Z14)	Piñón (Z14)	
MR	21	8A00 65955	1	Pignone uscita cambio (Z13)	Pinion (Z13)	Pignon (Z13)	Ritzel (Z13)	Piñón (Z13)	
MR	21	8000 65955	1	Pignone uscita cambio (Z12)	Pinion (Z12)	Pignon (Z12)	Ritzel (Z12)	Piñón (Z12)	
	22	60N1 01140	1	Vite	Screw	Vis	Schraube	Tornillo	
	23	8000 73649	1	Rosetta	Washer	Rondelle	Scheibe	Arandela	

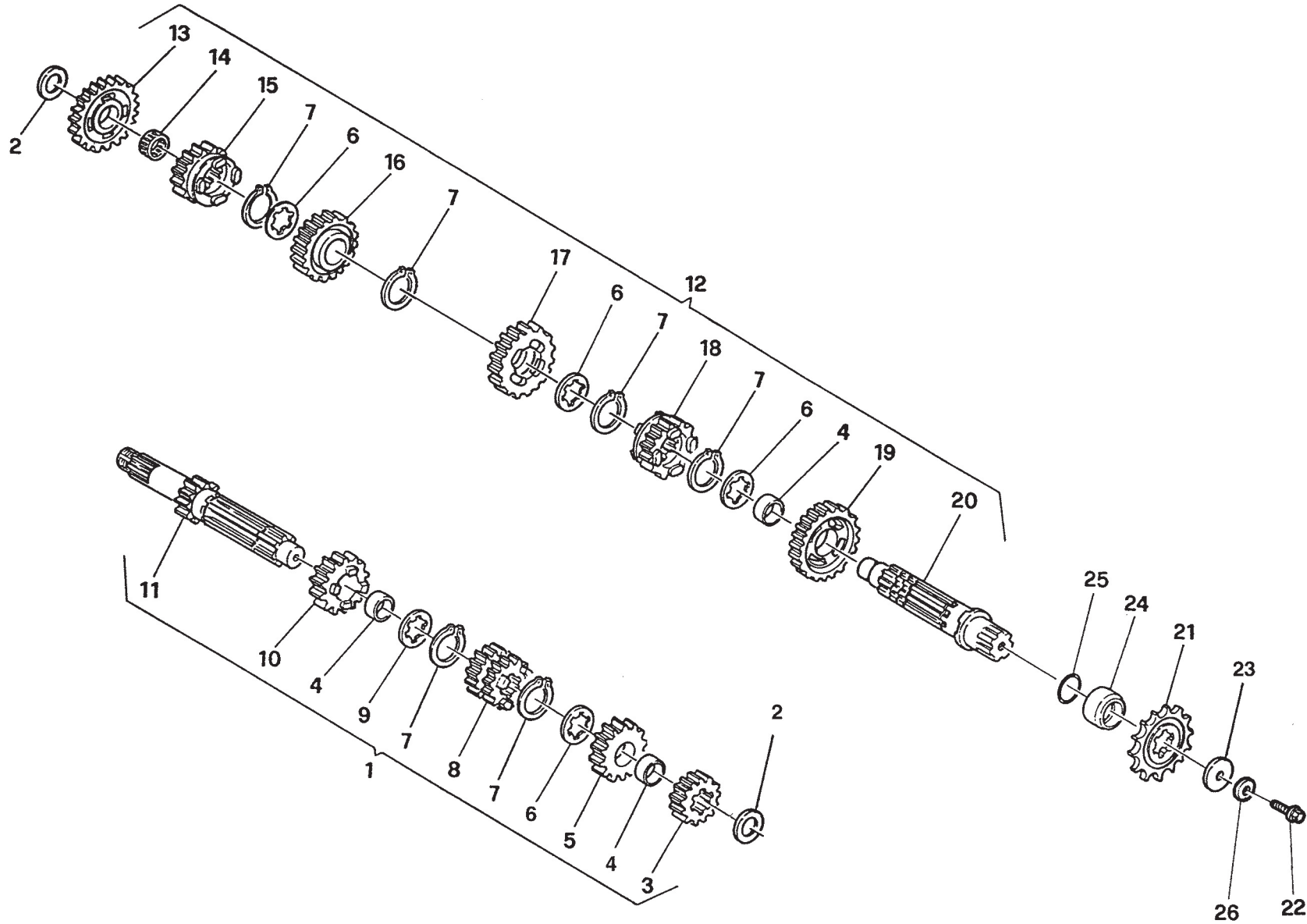

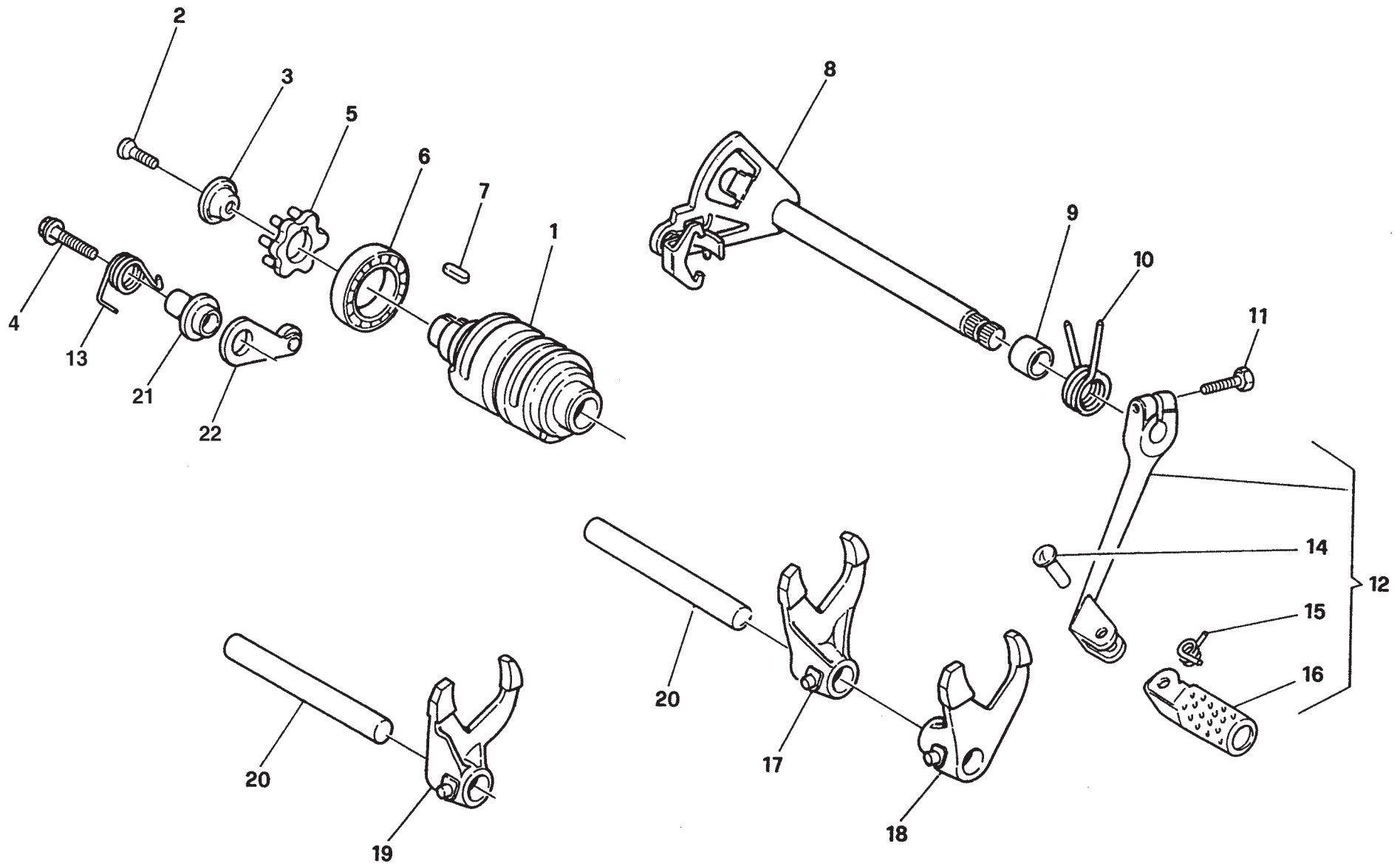



Note Notes Marke Notas	Pos. No. N. Index Pos.	N. Cod. Code No. Nr. Code Code Nr N. Cod.	Q.tà Q.ty Q.te M.ge C.ad	DENOMINAZIONE	NAME	DESIGNATION	BESCHREIBUNG	DENOMINACION	Validità Validity Validité Gültig Validez
	1	8000 77347	1	Albero comando forcelle	Fork driving shaft	Arbre de commande fourche	Steuerwelle f. Gabel	Eje mando horquilla	
	2	8000 47496	1	Vite	Screw	Vis	Schraube	Tornillo	
	3	8000 38708	1	Rosetta	Washer	Rondelle	Scheibe	Arandela	
	4	Z000 62730	1	Vite	Screw	Vis	Schraube	Tornillo	
	5	8000 38706	1	Rocchetto	Sprocket	Rochet	Spule	Piñon	
	6	8000 65884	1	Cuscinetto a sfere (ø25xø37x7 mm)	Ball bearing (ø25xø37x7 mm)	Roulement à billes (ø25xø37x7 mm)	Kugellager (ø25xø37x7 mm)	Cojinete de bolas (ø25xø37x7 mm)	
	7	8000 38707	1	Linguetta	Woodruff key	Clé woodruff	Federkeil	Lengüeta	
	8	8000 65975	1	Assieme selettore	Selector assembly	Ensemble sélecteur	Aggregat Wählschalter	Juego selector	
	9	8A00 46226	1	Distanziale	Spacer	Entretoise	Distanzstück	Separador	
	10	8000 46225	1	Molla	Spring	Ressort	Feder	Resorte	
	11	Z000 62728	1	Vite	Screw	Vis	Schraube	Tornillo	
E	12	8000 72431	1	Assieme leva comando cambio	Crank lever assy	Levier compl.	Hebel kpl.	Pedal mando cambio compl.	
	12	8000 76605	1	Assieme leva comando cambio	Crank lever assy	Levier compl.	Hebel kpl.	Pedal mando cambio compl.	
	13	8000 65921	1	Molla	Spring	Ressort	Feder	Resorte	
	14	8000 70217	1	Rivetto	Rivet	Rivet	Niet	Remarche	
	15	8000 70216	1	Molla	Spring	Ressort	Feder	Resorte	
	16	8000 70215	1	Pedalino	Pedal	Pedale	Pedal	Pedal	
	17	8000 76132	1	Forcella com. ingr. 1ª, 4ª vel.	Fork gear shifter 1st, 4th	Fourche 1ère, 4ème	Schaltgabel 1. 4. Gang	Horquilla compl. engr. 1°, 4°	
	18	8000 67011	1	Forcella ingr 2ª e 3ª veloc.	2nd & 3rd gear control fork	Fourche c.de 2ème & 3ème	Gabel Zahnr. 2. & 3. Geschw.	Horquilla engr. 2° y 3° vel.	
	19	8000 76133	1	Forcella ingr.5ª e 6ª velocità	5th & 6th gear control fork	Fourche c.de 5ème & 6ème	Gabel Zahnr. 5. & 6. Geschw.	Horquilla engr. 5° y 6° vel.	
	20	8000 35876	2	Perno forcella	Pin	Pivot	Stift	Perno	
	21	8000 66962	1	Bussola	Bushing	Douille	Buchse	Manguito	
	22	8A00 65895	1	Saltarello fissa marce	Gear fixing click	Cliquet	Strumhaken	Salt. fijo marchas	



WRE 125 - SMS 125 / 2011

TAVOLA
DRAWING
TABLE
BILD
TABLA

10

LUBRIFICAZIONE - OIL PUMP AND DRIVE
PUMPE HUILE - MOTORSCHMIERUNG
LUBRIFICATION

Note Notes Marke Notas	Pos. No. N. Index Pos.	N. Cod. Code No. Nr. Code Code Nr N. Cod.	Q.tà Q.ty Q.te M.ge C.ad	DENOMINAZIONE	NAME	DESIGNATION	BESHREIBUNG	DENOMINACION	Validità Validity Validité Gültig Validez
	1	8000 A9206	1	Piastra	Plate	Plaque	Platte	Placa	
	2	60ND 02504	1	Vite	Screw	Vis	Schraube	Tornillo	
	3	8A00 A8673	1	Pompa olio completa	Oil pump assy.	Pompe à huile compl.	Ölpumpe Kpl.	Bomba aceite completa	
	4	8000 A8674	1	Pompa olio elettrica	Electric oil pump	Pompe à huile électrique	Elektrisch Ölpumpe	Bomba aceite electrica	
	5	9472 00035	1	Condotto (L=85 mm)	Hose (L=85 mm)	Conduit (L=85 mm)	Rohr (L=85 mm)	Conducto (L=85 mm)	
	6	Z000 67997	1	Vite (M5x12)	Screw (M5x12)	Vis (M5x12)	Schraube (M5x12)	Tornillo (M5x12)	
	7	8A00 A8675	1	Condotto (L=420 mm)	Hose (L=420 mm)	Conduit (L=420 mm)	Rohr (L=420 mm)	Conducto (L=420 mm)	
	8	8000 A8676	1	Condotto (L=40 mm)	Hose (L=40 mm)	Conduit (L=40 mm)	Rohr (L=40 mm)	Conducto (L=40 mm)	
A	8	8W00 68873	1	Condotto (L=40 mm)	Hose (L=40 mm)	Conduit (L=40 mm)	Rohr (L=40 mm)	Conducto (L=40 mm)	
	9	62ND 15519	1	Rosetta	Washer	Rondelle	Scheibe	Arandela	
	10	8000 A9519	1	Filtro olio	Oil filter	Filter huile	Ölfilter	Filtro aceite	
	11	8000 A9520	2	Fascetta	Clamp	Collier	Schelle	Banda	
	12	8000 94721	1	Serbatoio olio	Oil tank	Reservoir huile	Öltank	Depósito aceite	
	13	8000 H1686	1	Tappo	Plug	Bouchon	Verschluss	Tapón	
	14	8000 56722	1	Anello di tenuta	Seal ring	Bague d'étanchéité	Dichtungsring	Anillo de retención	
	15	8A00 81900	1	Interruttore livello olio	Oil level switch	Interrupteur du niveau d'huile	Schalter Oelstand	Interruptor nivel aceite	
	16	8000 H1777	1	Protezione condotto (L=160 mm)	Hose guard (L=160 mm)	Protection conduit (L=160 mm)	Rohrschutz (L=160 mm)	Protección conducto (L=160 mm)	
	17	8000 96739	1	Spessore elastico	Spacer	Entretoise	Distanzstück	Separador	
	18	8000 18922	1	Anello elastico	Split ring	Anneau ressort	Sprengring	Anillo elástico	
	19	8000 56460	1	Anello elastico	Split ring	Anneau ressort	Sprengring	Anillo elástico	
	20	8000 78031	1	Anello guida tubi	Ring	Bague	Ring	Anillo	
	21	8A00 42349	2	Anello elastico	Split ring	Anneau ressort	Sprengring	Anillo elástico	

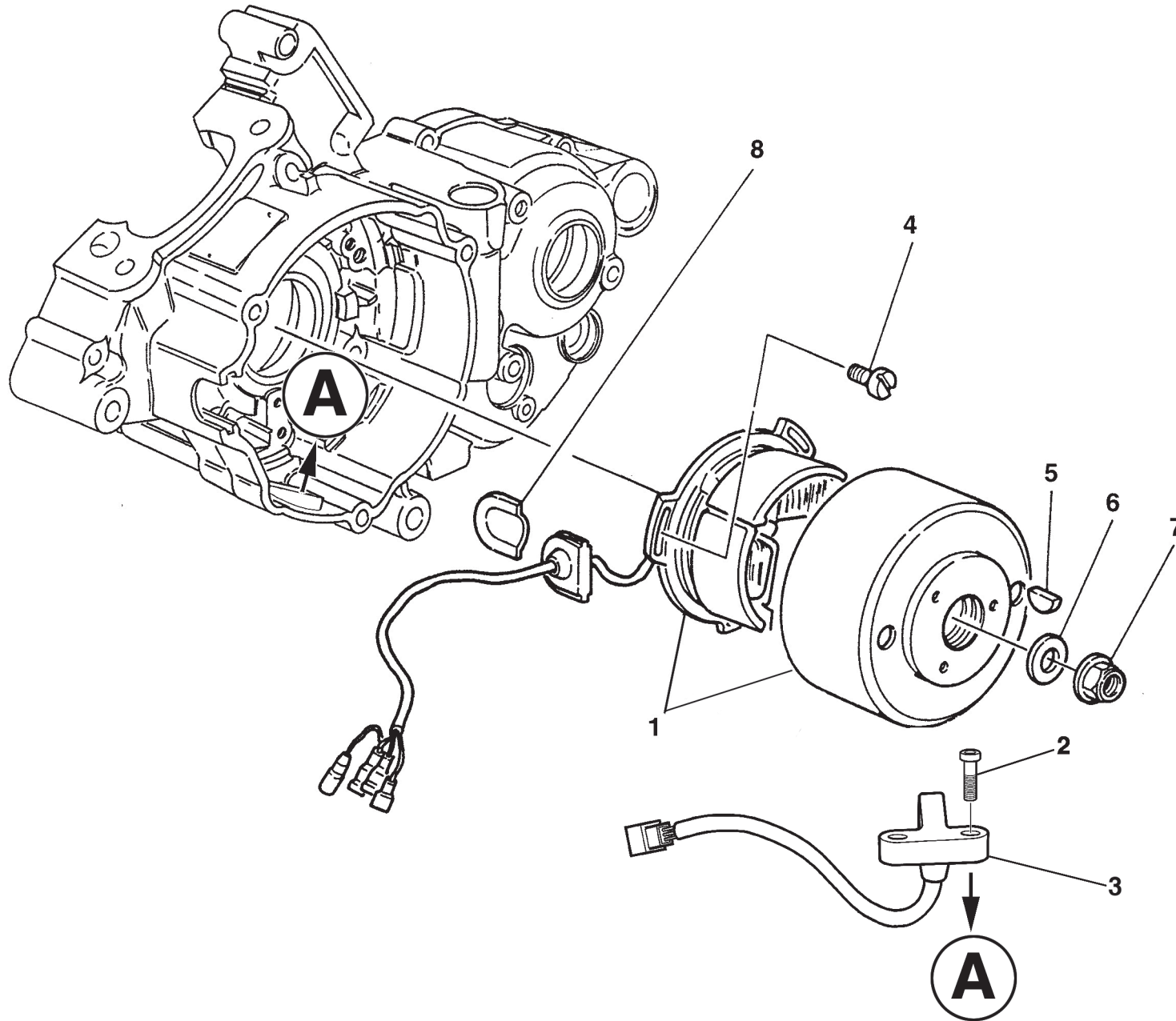

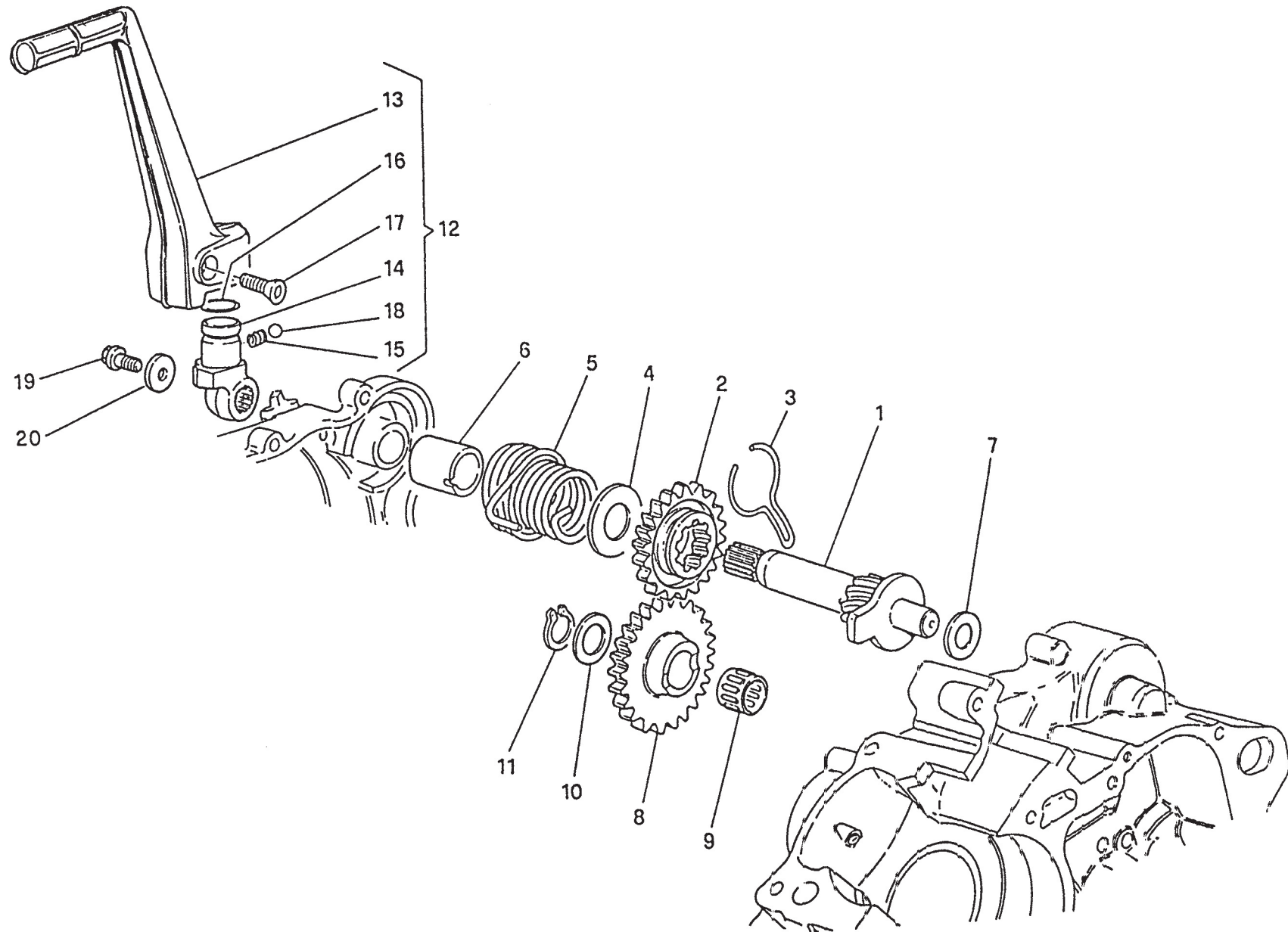



WRE 125 - SMS 125 / 2011

TAVOLA
DRAWING
TABLE
BILD
TABLA

11A

AVVIAMENTO A PEDALE - KICK STARTER
PEDAL DE MISE EN MARCHÉ - ANLASSER
PUESTA EN MARCHA A PEDAL

Note Notes Marke Notas	Pos. No. N. Index Pos.	N. Cod. Code No. Nr. Code Code Nr N. Cod.	Q.tà Q.ty Q.te M.ge C.ad	DENOMINAZIONE	NAME	DESIGNATION	BESHREIBUNG	DENOMINACION	Validità Validity Validité Gültig Validez
	1	8000 H5373	1	Albero avviamento	Starter crank shaft	Arbre de démarrage	Kickstarterwelle	Eje arranque	
	2	8000 67015	1	Ingranaggio (Z22)	Gear (Z22)	Engrenage (Z22)	Zahnrad (Z22)	Engranaje (Z22)	
	3	8000 67016	1	Molla di frizione	Spring	Resort	Feder	Resorte	
	4	8E00 18282	2	Rosetta	Washer	Rondelle	Scheibe	Arandela	
	5	8000 83095	1	Molla di ritorno leva	Spring	Resort	Feder	Resorte	
	6	8000 67020	1	Distanziale	Spacer	Entretoise	Distanzstück	Separador	
	7	8D00 10789	1	Rosetta	Washer	Rondelle	Scheibe	Arandela	
	8	8000 67013	1	Ingranaggio di rinvio (Z25)	Gear (Z25)	Engrenage (Z25)	Zahnrad (Z25)	Engranaje (Z25)	
	9	8A00 19946	1	Cuscinetto a rulli	Needle bearing	Roulement à l'aiguilles	Nadelkafig	Cojinete	
	10	8E00 01049	1	Rosetta	Washer	Rondelle	Scheibe	Arandela	
	11	66N0 21203	1	Anello elastico	Split ring	Anneau ressort	Sprengring	Anillo elástico	
	12	8000 H2159	1	Leva avviamento completa	Starter lever assy	Levier démarrage compl.	Hebelanlasser kpl.	Palanca arranque compl.	
	13	8000 H6158	1	Leva avviamento	Lever	Levier	Hebelanlasser	Palanca	
	14	8000 H2160	1	Mozzetto	Hub	Moyeau	Radnabe	Cubo	
	15	8000 66946	1	Molla	Spring	Ressort	Feder	Resorte	
	16	8000 36380	1	Anello OR	Ring	Anneau OR	RING OR	Anillo OR	
	17	8A00 38287	1	Vite	Screw	Vis	Schraube	Tornillo	
	18	6BN0 21506	1	Sfera	Ball	Bille	Kugel	Esfera	
	19	Z000 62725	1	Vite	Screw	Vis	Scchraube	Tornillo	
	20	Z000 30319	1	Rosetta	Washer	Rondelle	Scheibe	Arandela	

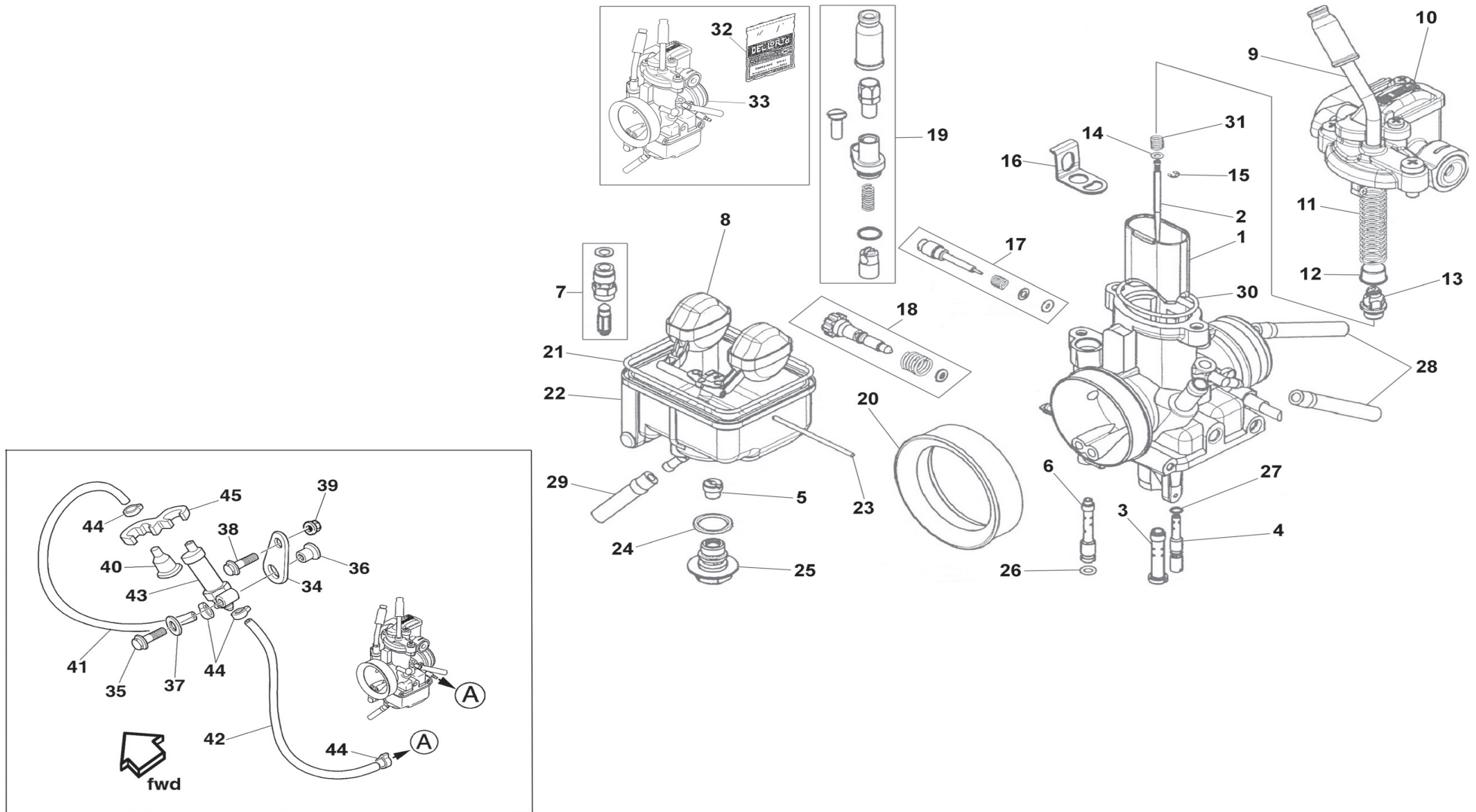



Note Notes Notes Marke Notas	Pos. No. N. Index Pos.	N. Cod. Code No. Nr. Code Code Nr N. Cod.	Q.tà Q.ty Q.te M.ge C.ad	DENOMINAZIONE	NAME	DESIGNATION	BESHREIBUNG	DENOMINACION	Validità Validity Validité Gültig Validez
	1	8000 B0789	1	Valvola gas (55)	Throttle valve (55)	Papillon de gaz (55)	Drosselklappe (55)	Válvula gaz (55)	
	2	8A00 35371	1	Spillo conico (D 48)	Needle (D 48)	Pointeau conique (D 48)	Kon. Nadel (D 48)	Pasador cónico (D 48)	
	3	8000 B0790	1	Polverizzatore (HN 268)	Fuel nozzle (HN 268)	Pulvérisateur (HN 268)	Einspritzdüse (HN 268)	Pulverizador (HN 268)	
	4	8000 B0791	1	Getto emuls. minimo (U 38)	Emulsifier (U 38)	Emulsionneur (U 38)	Mischer (U 38)	Emulsionador (U 38)	
	5	8000 12041	1	Getto massimo (142)	Main jet (142)	Gicleur principal (142)	Hauptdüse (142)	Chiclé máximo (142)	
	6	80A0 12032	1	Getto avviamento (60)	Starting jet (60)	Gicleur de starter (60)	Starterdüse (60)	Chiclé arranque (60)	
	7	8000 33109	1	Valvola a spillo (300)	Needle valve (300)	Soupape à pointeau (300)	Nadelventi (300)(300)	Válvula de aguja (300)	
	8	80B0 35357	1	Galleggiante (g 6,5)	Float (g 6,5)	Flotteur (g 6,5)	Schwimmer (g 6,5)	Flotador (g 6,5)	
	9	8000 B0792	1	Kit tubetto	Pipe Kit	Kit tuyau	Rohr Kit	Kit tubo	
	10	8000 B0793	1	Coperchio con T.P.S.	Cover with T.P.S.	Couvercle avec T.P.S.	Deckel mit T.P.S.	Tapa con T.P.S.	
	11	8000 B0794	1	Molla	Spring	Ressort	Feder	Resorte	
	12	8000 B0795	1	Fondello	End plate	Culot	Endscheibe	Cubeta	
	13	8000 B0796	1	Nipplo	Nipple	Nipple	Nippel	Nipple	
	14	8000 B0797	1	Rosetta piana	Washer	Rondelle	Scheibe	Arandela	
	15	8000 35353	1	Fermaglio spillo conico	Retainer	Arret	Klammer	Pasador cónico	
	16	8000 B0798	1	Supporto leva T.P.S.	T.P.S. lever holder	Support levier T.P.S.	T.P.S. Hebelhalterung	Soporte palanca T.P.S.	
	17	8000 B0799	1	Kit vite minimo	Idle screw Kit	Kit vis ralenti	Minimaldrehzahlschraube Kit	Kit tornillo ralenti	
	18	8000 B0800	1	Kit vite valvola gas	Throttle valve screw Kit	Kit vis papillon de gaz	Gasventilschraube Kit	Kit tornillo válvula gaz	
	19	8000 B0801	1	Kit starter	Starter Kit	Kit starter	Starter Kit	Kit arranque	
	20	8000 B0802	1	Raccordo	Union	Raccord	Anschluss	Empalme	
H	21		1	Guarnizione	Gasket	Garniture	Dichtung	Junta	
	22	8000 71741	1	Vaschetta	Chamber	Cuvette	Becken	Cubeta	
	23	8000 32867	1	Perno galleggiante	Pin	Pivot	Bolzen	Perno	
H	24		1	Guarnizione	Gasket	Garniture	Dichtung	Junta	
	25	8000 49531	1	Tappo	Plug	Bouchon	Verschluss	Tapón	
H	26		1	Guarnizione	Gasket	Garniture	Dichtung	Junta	
H	27		1	Guarnizione	Gasket	Garniture	Dichtung	Junta	
	28	8000 B0805	2	Tubetto (L=405 mm)	Pipe	Tuyau	Rohr	Tubo	

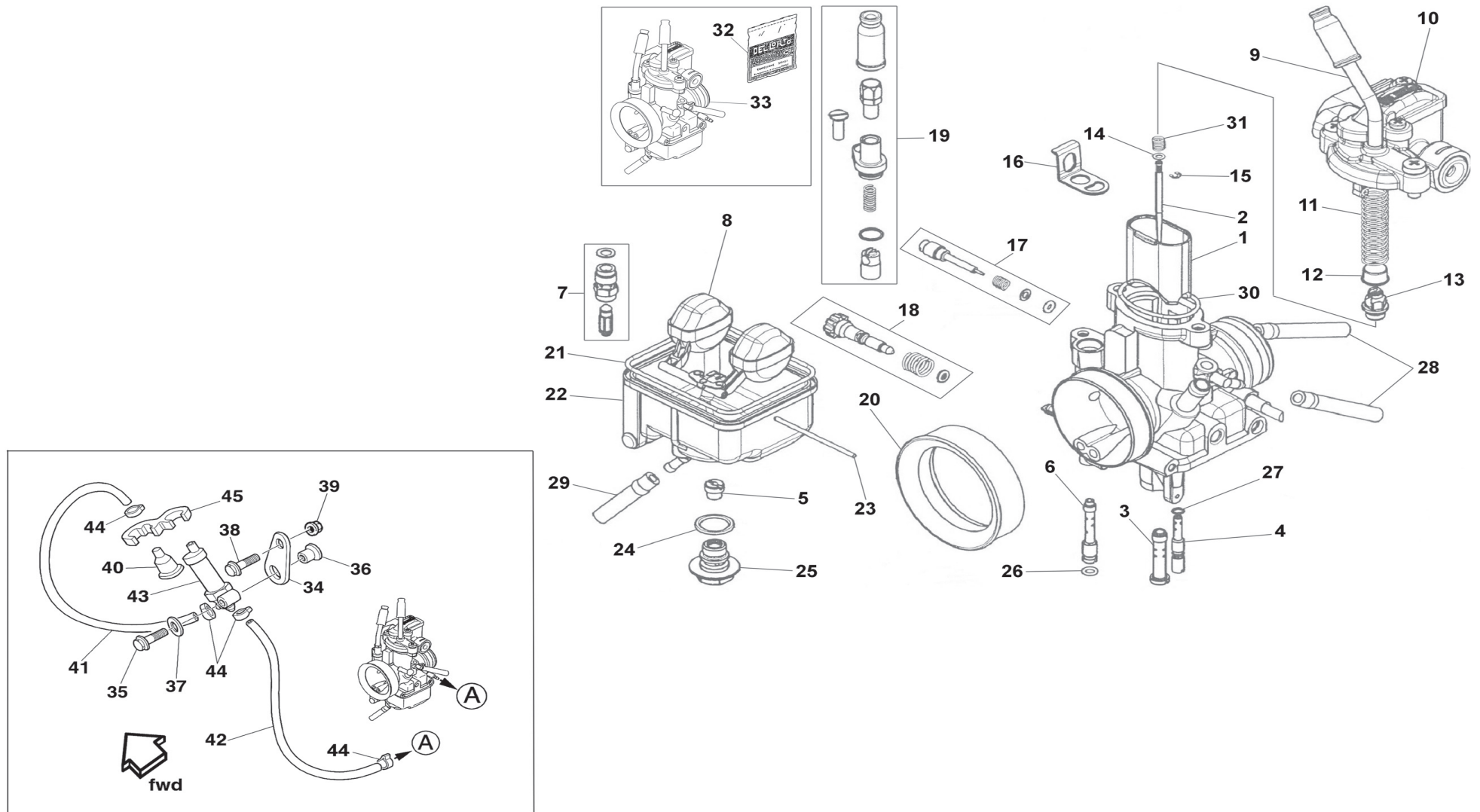



Note Notes Notas	Pos. No. N. Index Pos.	N. Cod. Code No. Nr. Code Code Nr N. Cod.	Q.tà Q.ty Q.te M.ge C.ad	DENOMINAZIONE	NAME	DESIGNATION	BESHREIBUNG	DENOMINACION	Validità Validity Validité Gültig Validez
	29	8000 B0806	1	Tubetto (L=260 mm)	Pipe	Tuyau	Rohr	Tubo	
H	30		1	Guarnizione	Gasket	Garniture	Dichtung	Junta	
	31	8000 B0807	1	Molla	Spring	Ressort	Feder	Resorte	
	32	8000 B0808	1	Gruppo guarnizioni	Gasket set	Groupe garnitures	Dichtungssatz	Grupo juntas	
	33	8000 A8717	1	Ass. carburatore	Carburetor assy.	Carburateur complet	Vergaser, kpl.	Carburador compl.	
	34	8000 A9345	1	Piastrina	Plate	Plaque	Platte	Placa	
	35	ZA00 67545	1	Vite (M6x35 mm)	Screw (M6x35 mm)	Vis (M6x35 mm)	Schraube (M6x35 mm)	Tornilo (M6x35 mm)	
	36	8000 48245	1	Dado	Nut	Ecrou	Mutter	Tuerca	
	37	Z000 48814	1	Rosetta	Washer	Rondelle	Scheibe	Arandela	
	38	ZB00 62733	1	Vite (M8x45 mm)	Screw (M8x45 mm)	Vis (M8x45 mm)	Schraube (M8x45 mm)	Tornilo (M8x45 mm)	
	39	8000 43928	1	Dado	Nut	Ecrou	Mutter	Tuerca	
	40	8000 A8689	1	Filtro	Filter	Filtre	Filter	Filtro	
	41	8A00 A8692	1	Condotto (L=180 mm)	Hose (L=180 mm)	Conduit (L=180 mm)	Rohr (L=180 mm)	Conducto (L=180 mm)	
	42	8B00 A8692	1	Condotto (L=250 mm)	Hose (L=250 mm)	Conduit (L=250 mm)	Rohr (L=250 mm)	Conducto (L=250 mm)	
	43	8000 A8688	1	Valvola solenoide	Solenoid valve	Soupape solénoide	Solenoid sicherung	Válvula solenoide	
	44	8000 33273	4	Fascetta	Clamp	Collier	Schelle	Banda	
	45	8000 88597	1	Guidatubazione	Hose guide	Guide conduit	Rohrführung	Guía conducto	

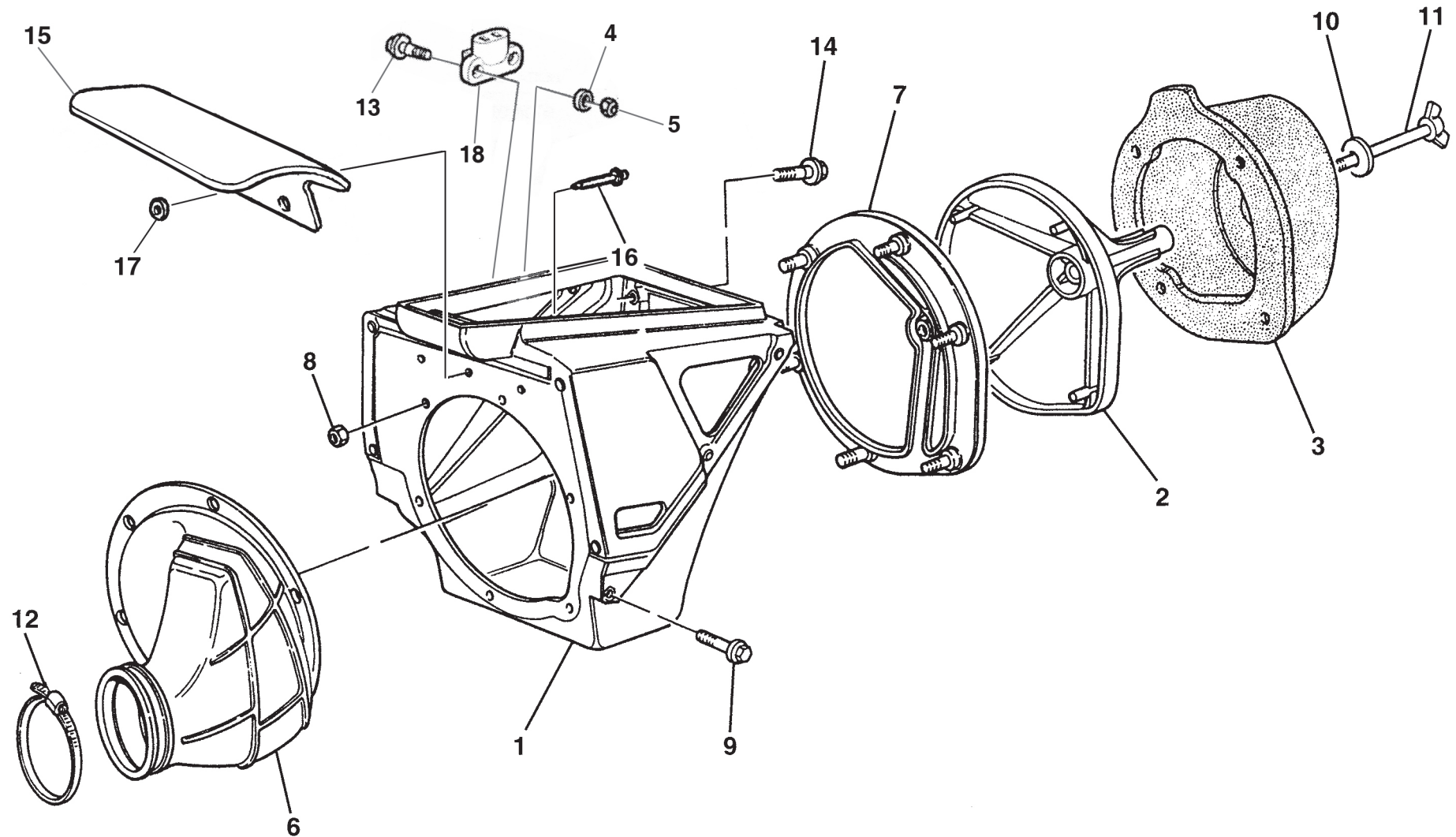

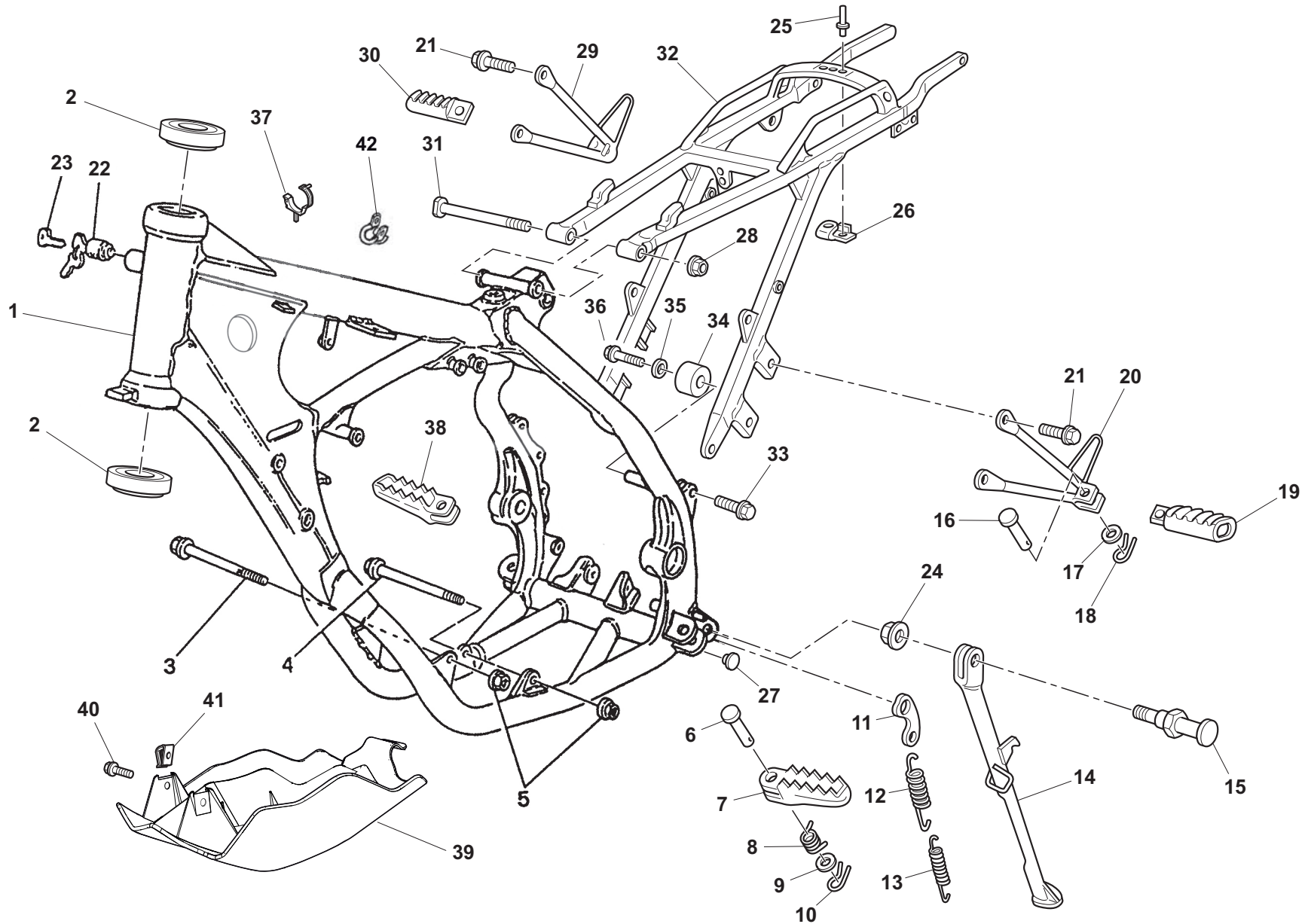

Note Notes Notes Marke Notas	Pos. No. N. Index Pos.	N. Cod. Code No. Nr. Code Code Nr N. Cod.	Q.tà Q.ty Q.te M.ge C.ad	DENOMINAZIONE	NAME	DESIGNATION	BESHREIBUNG	DENOMINACION	Validità Validity Validité Gültig Validez
	1	8000 H5349	1	Parte anteriore compl.	Frame front side assy	Chassis av. compl.	Rahmen kpl.	Cuadro anterior compl.	
	2	8000 87243	2	Cuscinetto a rulli conici (ø25xø50x17,5 mm)	Bearing (ø25xø50x17,5 mm)	Roulement à rouleaux coniques (ø25xø50x17,5 mm)	Lager (ø25xø50x17,5 mm)	Cojinete de rodillos cónicos (ø25xø50x17,5 mm)	
	3	YN00 73458	1	Perno ant. fiss.motore (M8x120 mm)	Pin (M8x120 mm)	Pivot (M8x120 mm)	Bolzen (M8x120 mm)	Perno (M8x120 mm)	
E	4	8B00 73458	1	Perno fiss. motore (M8x130 mm)	Pin (M8x130 mm)	Pivot (M8x130 mm)	Bolzen (M8x130 mm)	Perno (M8x130 mm)	
	4	YP00 73458	1	Perno fiss. motore (M8x135 mm)	Pin (M8x135 mm)	Pivot (M8x135 mm)	Bolzen (M8x135 mm)	Perno (M8x135 mm)	
	5	Y000 43928	2	Dado	Nut	Ecrou	Mutter	Tuerca	
	6	Y000 73140	2	Perno	Pin	Pivot	Bolzen	Perno	
	7	80A0 89962	1	Pedana sinistra	L.H. foot-rest	Repose-pieds	L. Fussraste	Pedal del. i.comp.	
	8	8000 96908	1	Molla Dx	R.H. spring	Ressort D.	Feder Rechte	Resorte der.	
	8	8000 96907	1	Molla Sx	L.H. spring	Ressort G.	Feder Linke	Resorte iz.	
	9	ZA00 01815	2	Rosetta	Washer	Rondelle	Scheibe	Arandela	
	10	64ND 20068	2	Copiglia	Split pin	Goupille	Splint	Clavija	
	11	8000 A0267	1	Piastrina	Plate	Plaque	Platte	Plaque	
	12	8000 62675	1	Molla esterna	Spring	Ressort	Feder	Resorte	
	13	8000 62676	1	Molla interna	Spring	Ressort	Feder	Resorte	
W	14	8000 H4858	1	Gamba laterale	Side stand	Bequille lat.	Seitenständer	Horquilla lateral	
M	14	8B00 H4858	1	Gamba laterale	Side stand	Bequille lat.	Seitenständer	Horquilla lateral	
	15	8A00 97976	1	Vite	Screw	Vis	Schraube	Tornillo	
	16	8000 41459	2	Perno	Pin	Pivot	Bolzen	Perno	
	17	62ND 15504	2	Rosetta	Washer	Rondelle	Scheibe	Arandela	
	18	64ND 20048	2	Copiglia	Split pin	Goupille	Splint	Clavija	
	19	8000 66651	1	Poggiapiedi passeggero Sx.	L.H. foot rest support	Support repose pied G.	L. Fussraster	Posapie izq.	
	20	8A00 75432	1	Supporto Sx.	L.H. support	Support G.	Halterung L.	Soporte izq.	
	21	ZB00 69056	4	Vite	Screw	Vis	Schraube	Tornillo	
	22	8000 43391	1	Serratura antifurto completa	Anti-left lock assy	Serrure anti-vol compl.	Sicherheitsschloss kpl.	Cerradura compl.	
	23	8000 35531	1	Chiave grezza	Raw key	Clef primitive	Schlüssel	Llave	
	24	Y000 43928	1	Dado	Nut	Ecrou	Mutter	Tuerca	
	25	8000 33373	2	Rivetto	Rivet	Rivet	Niet	Remache	
	26	8000 69150	1	Piastrina	Plate	Plaquette	Plättchen	Placa	
	27	8000 H3511	2	Tappo	Plug	Bouchon	Verschluss	Tapón	
	28	Y000 43928	1	Dado autobloccante	Nut	Ecrou	Mutter	Tuerca	
	29	8000 H4165	1	Supporto Dx	R.H. support	Support D.	Halterung R.	Soporte der.	

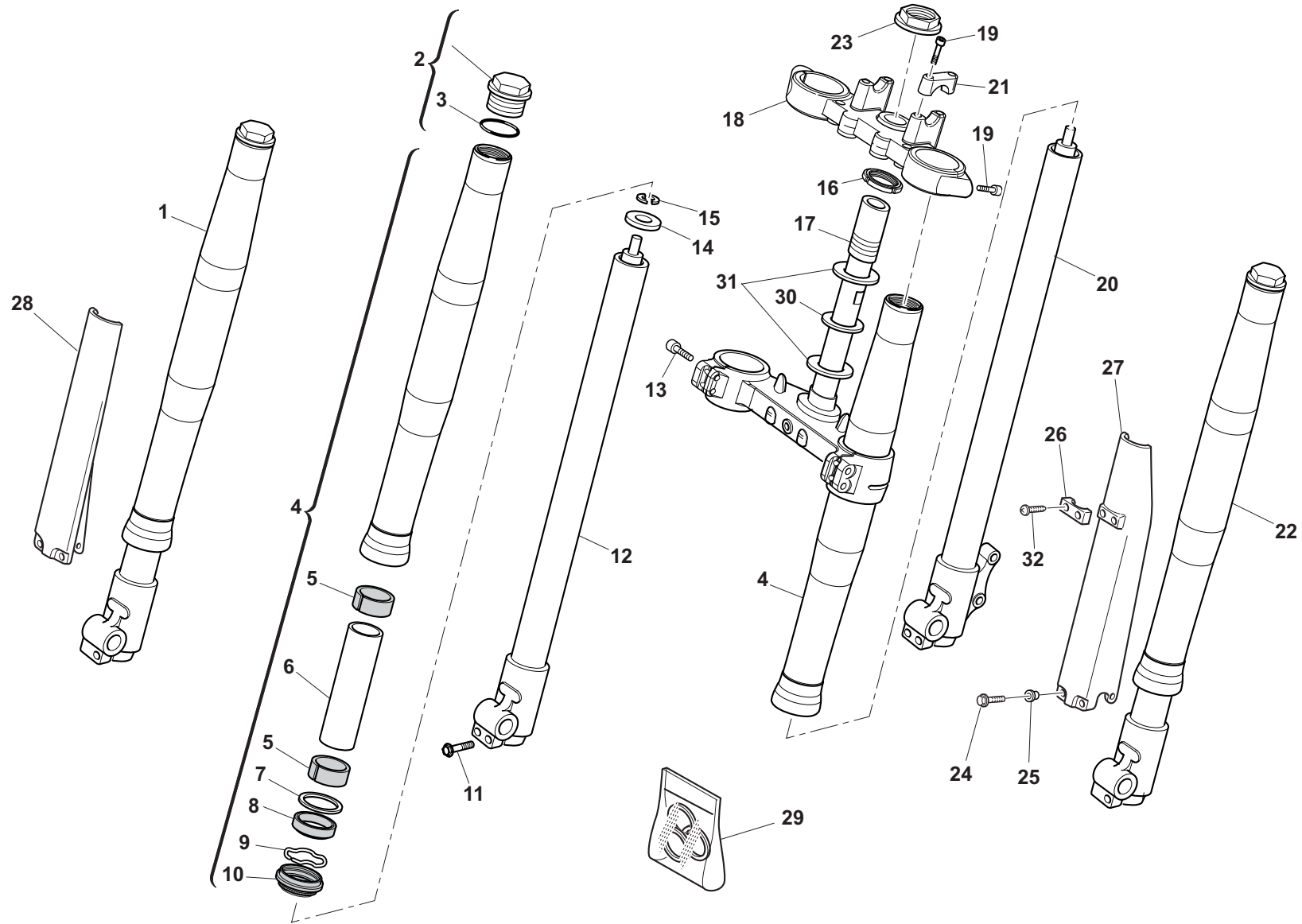



WRE 125 - SMS 125 / 2011

TAVOLA
DRAWING
TABLE
BILD
TABLA

15

SOSPENSIONE ANTERIORE - FRONT FORK ASSEMBLY
SUSPENSION AVANT - VORDERTELESKOPGABEL
SUSPENSION DELANTERA

Note Notes Marke Notas	Pos. No. N. Index Pos.	N. Cod. Code No. Nr. Code Code Nr N. Cod.	Q.tà Q.ty Q.te M.ge C.ad	DENOMINAZIONE	NAME	DESIGNATION	BESHREIBUNG	DENOMINACION	Validità Validity Validité Gültig Validez
	1	8000 H5759	1	Stelo Dx compl.	R.H. slider assy	Montant D. compl.	Bein, Kpl. R.	Deslizable der. compl.	
	2	8000 77362	2	Gruppo tappo	Plug assy.	Groupe bouchon	Verschlussgruppe Kpl.	Grupo tapón	
	3	8000 77360	2	Anello OR	O-Ring	Bague OR	O Ring	Anillo OR	
	4	8000 H5761	2	Portastelo completo	Pipe assy	Groupe tuyau compl.	Rohrgruppe Kpl	Grupo tubo compl.	
	5	8000 70966	4	Boccola	Bushing	Douille	Buchse	Buje	
	6	8000 79005	2	Distanziale	Spacer	Entretoise	Distanzstück	Separador	
	7	8000 77378	2	Rondella	Washer	Rondelle	Scheibe	Arandela	
	8	8000 37977	2	Anello di tenuta	Seal ring	Bague d'étancheite	Dichtring	Anillo de retención	
	9	8000 55520	2	Anello ritegno paraolio	Circlip	Circlip	Haltering	Retenedor	
	10	8000 87038	2	Parapolvere	Boots	Para-poudr	Schutzhaube	Para-polvo	
	11	80A0 75097	4	Vite	Screw	Vis	Schraube	Tornillo	
	12	8000 97727	1	Gamba Dx completa	R.H. fork leg assy	Fourche complète D.	Telegabel Kpl. R.	Horquilla derech. compl.	
	13	8000 62796	4	Vite	Screw	Vis	Schraube	Tornillo	
	14	8000 79006	2	Anello	Ring	Anneau	Ring	Anillo	
	15	8000 79007	4	Rondella	Washer	Rondelle	Scheibe	Arandela	
	16	8A00 87717	1	Ghiera	Ring nut	Embout	Nutmutter	Virola	
	17	8000 H5757	1	Base di sterzo con perno	Steering crown with pin	Socle de direction avec pivot	Gabelbrücke mit Bolzen	Base de dirección con perno	
	18	8000 H5758	1	Testa di sterzo	Steering head	Tête direction	Lenkkopf	Cabezal de dirección	
	19	8000 90093	6	Vite	Screw	Vis	Schraube	Tornillo	
	20	8000 97726	1	Gamba Sx completa	L.H. fork leg assy	Fourche compl. G.	Telegabel, Kpl. L.	Horquill izq. compl.	
	21	8000 H5752	2	Cavallotto	U-bolt	Cavalier	Bügelbolzen	Caballete	
	22	8000 H5760	1	Stelo Sx compl.	L.H. slider assy	Montant G. compl.	Bein, Kpl. L.	Deslizable izrda. compl.	
	23	8A00 69315	1	Dado	Nut	Ecrou	Mutter	Tuerca	
	24	Z000 67997	6	Vite	Screw	Vis	Schraube	Tornillo	
	25	8000 69282	6	Bussola	Bushing	Douille	Buchse	Manguito	
	26	80A0 A0633	2	Passacavo	Fairlead	Passe-câble	Kabelführung	Prensa-cable	
WM	27	8000 H6084	1	Protezione steli Sx NERO	Guard L.H. BLACK	Protection D NOIR	Schutz L. SCHWARZ	Protección izq. NEGRO	
M	27	8000 69337	1	Protezione steli Sx NERO per versione NERO/BIANCO	Guard L.H. BLACK for BLACK/WHITE version	Protection D NOIR pour version NOIR/BLANC	Schutz L. SCHWARZ für Version SCHWARZ/WEISS	Protección izq. NEGRO para versión NEGRO/BLANCO	
	28	80C0 69338	1	Protezione steli Dx NERO	Guard R.H. BLACK	Protection G NOIR	Schutz R. SCHWARZ	Protección der. NEGRO	
	29	8000 79008	1	Gruppo guarnizioni	Gasket set	Grupe garniture	Dichtungssatz	Grupo juntas	
	30	Z000 87736	1	Rosetta	Washer	Rondelle	Scheibe	Arandela	
	31	8000 87745	2	Parapolvere	Boots	Para-poudre	Schutzhaube	Para-polvo	

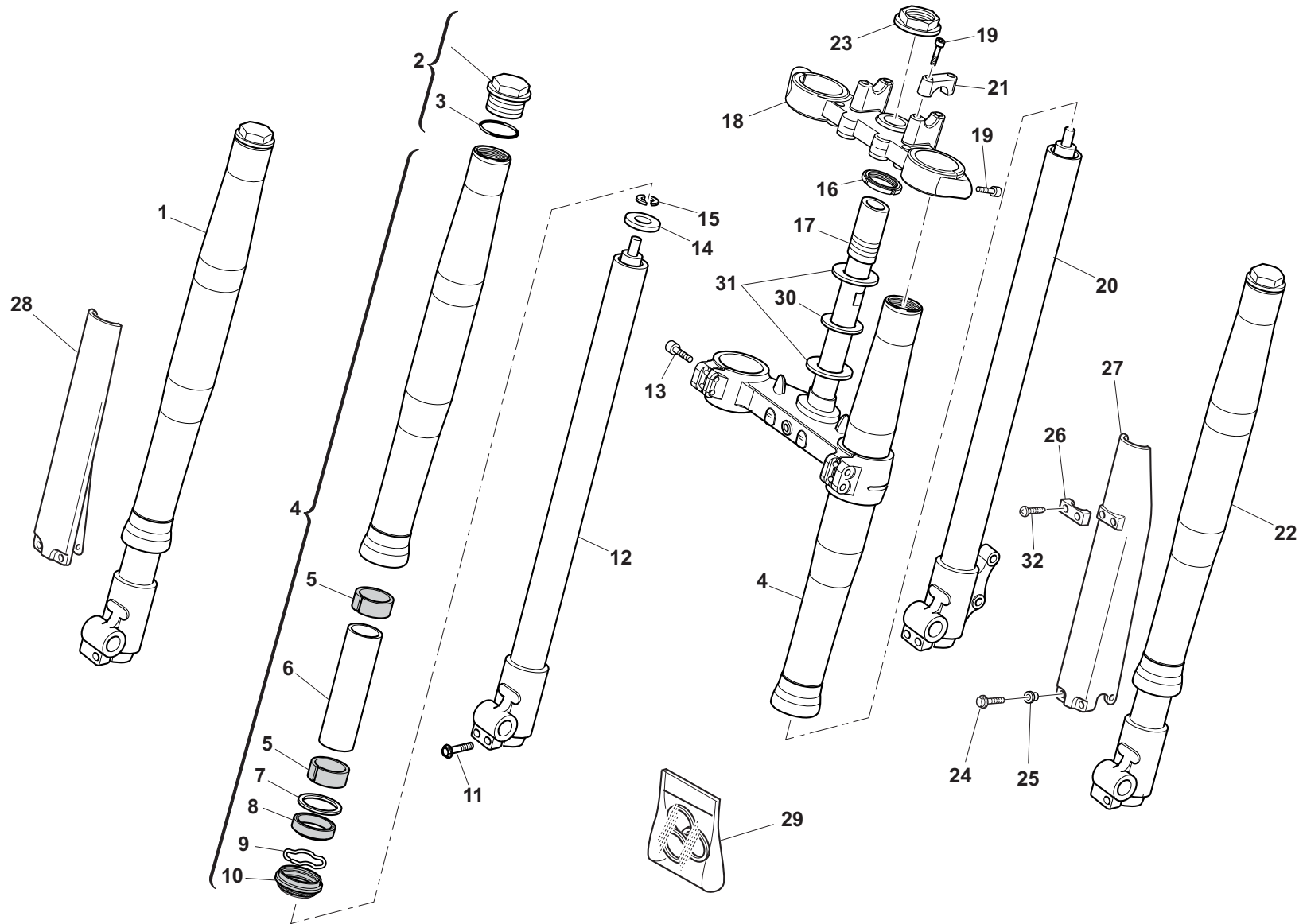

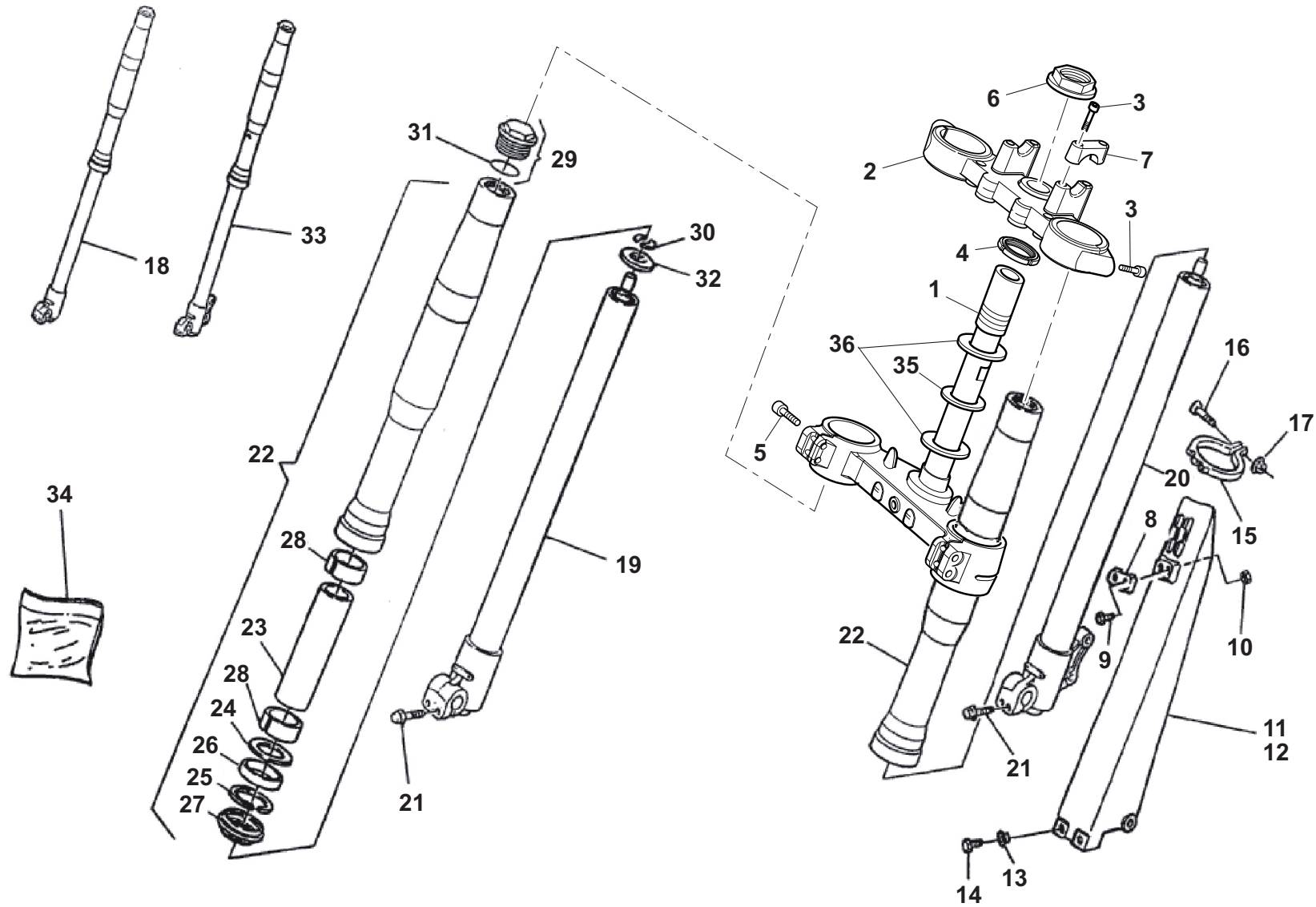

Note Notes Notas	Pos. No. N. Index Pos.	N. Cod. Code No. Nr. Code Code Nr N. Cod.	Q.tà Q.ty Q.te M.ge C.ad	DENOMINAZIONE	NAME	DESIGNATION	BESHREIBUNG	DENOMINACION	Validità Validity Validité Gültig Validez
	1	8000 H5757	1	Base di sterzo con perno	Steering crown with pin	Socle de direction avec pivot	Gabelbrücke mit Bolzen	Base de dirección con perno	
	2	8000 H5758	1	Testa di sterzo	Steering head	Tête direction	Lenkkopf	Cabezal de dirección	
	3	8000 90093	6	Vite	Screw	Vis	Schraube	Tornillo	
	4	8A00 87717	1	Ghiera	Ring nut	Embout	Nutmutter	Virola	
	5	8000 62796	4	Vite	Screw	Vis	Schraube	Tornillo	
	6	8A00 69315	1	Dado	Nut	Ecrou	Mutter	Tuerca	
	7	8000 H5948	2	Cavallotto	U-bolt	Cavalier	Bügelbolzen	Caballete	
	8	80A0 A0633	1	Piastrina Sx NERO	Plate BLACK	Plaque NOIR	Platte SCHWARZ	Placa NEGRO	
	9	8A00 67997	2	Vite	Screw	Vis	Schraube	Tornillo	
	10	8000 61355	2	Dado	Nut	Ecrou	Mutter	Tuerca	
	11	8000 H6084	1	Protezione Sx NERO	Guard L.H. BLACK	Protection D. NOIR	Schutz L. SCHWARZ	Protección iz. NEGRO	
	12	80C0 69338	1	Protezione Dx NERO	Guard R.H. BLACK	Protection G. NOIR	Schutz R. SCHWARZ	Protección derecho NEGRO	
	13	8000 67997	6	Vite	Screw	Vis	Schraube	Tornillo	
	14	8000 69282	6	Bussola	Bushing	Douille	Buchse	Manguito	
	15	8BA0 70558	2	Anello	Ring	Bague	Ring	Anillo	
	16	8B00 66525	2	Vite	Screw	Vis	Schraube	Tornillo	
	17	8000 40718	2	Dado	Nut	Ecrou	Mutter	Tuerca	
	18	8A00 78996	1	Gamba Dx. compl.	R.H. fork leg assy	Fourche complete D.	Telegabel Kpl. R.	Horquilla D compl.	
	19	8000 97727	1	Gruppo pompante DX	Pumping element R	Element de pompage D	Pumpenelement R	Bombeadora compl. D	
	20	8000 97726	1	Gruppo pompante SX	L pumping element	Element de pompage G	Pumpenelement L	Bombeadora compl. I	
	21	80A0 75097	4	Vite (M6x25 mm)	Screw (M6x25 mm)	Vis (M6x25 mm)	Schraube (M6x25 mm)	Tornillo (M6x25 mm)	
	22	8000 79004	2	Portastelo compl.	Comp. stem holder	Porte-tige compl.	Kpl. Schafthalter	Portavastago	
	23	8000 79005	2	Tubetto	Pipe	Tuyau	Rohr	Tubo	
	24	8000 77378	2	Scodellino	Cup	Cuvette	Teller	Cubeta	
	25	8000 55520	2	Anello elastico	Seal ring	Bague d'étanchéité	Dichtungsring	Anillo elástico	
*	26	8000 37977	2	Anello di tenuta	Seal ring	Bague d'étanchéité	Dichtungsring	Anillo de retención	
*	27	8000 87038	2	Raschiapolvere	Dust scraper	Racloir poudre	Pulverabschaber	Rascador de polvo	
	28	8000 70966	4	Boccola	Bush	Douille	Buchse	Casquillo	
	29	8000 77362	2	Tappo	Plug	Bouchon	Verschluss	Tapòn	
	30	8000 79007	4	Semirondella	Split washer	Demi-rondelle	Halbscheibe	Semiarandela	
*	31	8000 77360	2	Anello OR	O-Ring	Bague OR	O-Ring	Anillo OR	
	32	8000 79006	2	Anello	Ring	Bague	Ring	Anillo	
	33	8B00 78997	1	Gamba Sx. com.	Compl. L.H. leg	Jambe G. compl.	Kpl. L. Bein	Pata izq. compl.	

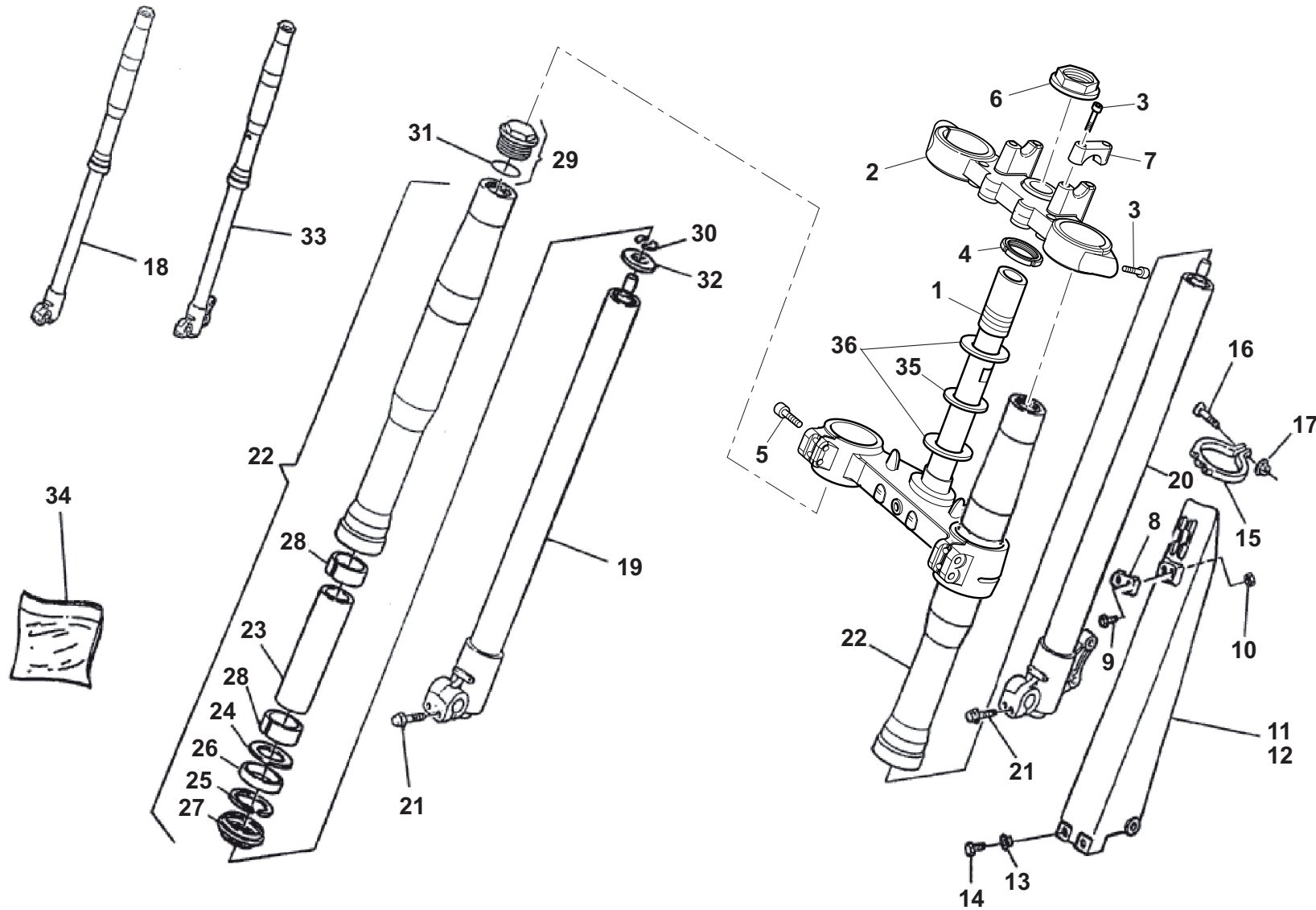

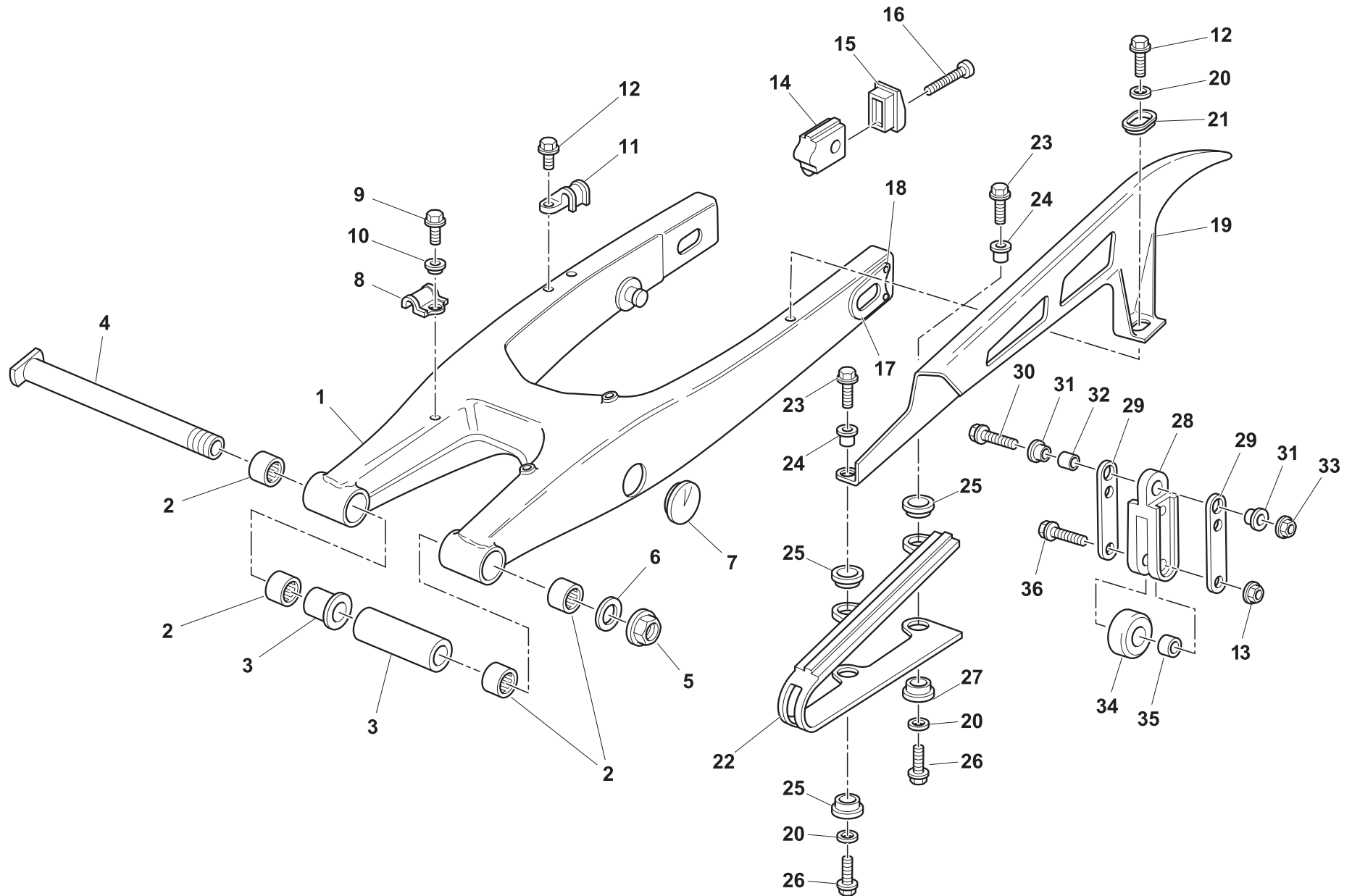



WRE 125 - SMS 125 / 2011

TAVOLA
DRAWING
TABLE
BILD
TABLA

16

FORCELLONE - SWING ARM
FOURCHE - GABEL
HORQUILLA

Note Notes Notes Marke Notas	Pos. No. N. Index Pos.	N. Cod. Code No. Nr. Code Code Nr N. Cod.	Q.tà Q.ty Q.te M.ge C.ad	DENOMINAZIONE	NAME	DESIGNATION	BESHREIBUNG	DENOMINACION	Validità Validity Validité Gültig Validez
	1	8A00 74794	1	Forcellone completo	Compl. fork	Fourche complete	Gabel, Kpl.	Horquilla compl.	
	2	8000 76283	4	Gabbia a rullini	Needle cage	Cage à aiguilles	Nadelkaefig	Jaula de agujas del cojinete	
	3	8000 71621	2	Bussola (L= 49,5 mm) Sx	Bushing (L= 49,5 mm) Left	Douille (L= 49,5 mm) Gouche	Buchse (L= 49,5 mm) SX	Buje (L= 49,5 mm) Izquierda	
	4	8000 71620	1	Perno forcellone	Fork pin	Pivot fourche	Gabelbolzen	Perno horquilla	
	5	Z000 71623	1	Dado	Nut	Ecrou	Mutter	Tuerca	
	6	8000 32388	1	Rosetta	Washer	Rondelle	Scheibe	Arandela	
	7	80A0 74388	2	Tappo	Plug	Bouchon	Verschluss	Tapón	
	8	80A0 73456	1	Guidacavo	Cable guide	Guide câble	Kabelführung	Guía-cable	
	9	Z000 67997	1	Vite	Screw	Vis	Schraube	Tornillo	
	10	8000 69282	1	Bussola	Bushing	Douille	Buchse	Buje	
	11	80A0 59299	1	Fermatubo posteriore	Cable guide	Guide câble	Kabelführung	Guía-cable	
	12	Z000 20536	3	Vite	Screw	Vis	Schraube	Tornillo	
	13	Z000 61313	2	Dado	Nut	Ecrou	Mutter	Tuerca	
	14	8000 74815	2	Tendicatena	Chain adjuster	Tendeur de chaine	Kettenspanner	Tensor de cadena	
	15	80C0 74816	2	Coperchietto	Cover	Couvercle	Deckel	Tapa	
	16	Z000 62400	2	Vite	Screw	Vis	Schraube	Tornillo	
	17	8A00 62802	2	Piastrina	Plate	Plaque	Platte	Placa	
	18	8000 33372	4	Rivetto	Rivet	Rivet	Niet	Remache	
	19	8AB0 76028	1	Copricatena	Chain guard	Carter de chaine	Kettenkasten	Cubre-cadena	
	20	Z000 36137	3	Rosetta	Washer	Rondelle	Scheibe	Arandela	
	21	8000 H3033	1	Scodellino	Cup	Couvette	Teller	Cubeta	
	22	8000 72884	1	Pattino catena	Chain slider	Glissière de chaine	Gleitbahn	Platode cadena	
	23	ZC00 67997	2	Vite	Screw	Vis	Schraube	Tornillo	
	24	8A00 69282	2	Bussola	Bushing	Douille	Buchse	Buje	
	25	8000 H3034	3	Scodellino	Cup	Couvette	Teller	Cubeta	
	26	ZA00 67997	2	Vite	Screw	Vis	Schraube	Tornillo	
	27	8000 H3033	1	Scodellino	Cup	Couvette	Teller	Cubeta	
	28	8000 72874	1	Guidacatena	Chain guide	Guide-chaine	Kettenführung	Guía-cadena	
	29	8000 76002	2	Piastra d'attacco	Plate	Plaque	Platte	Placa	
	30	Z000 62795	1	Vite	Screw	Vis	Schraube	Tornillo	
	31	8A00 H3019	2	Bussola	Bushing	Douille	Buchse	Buje	
	32	8A00 36984	1	Bussola	Bushing	Douille	Buchse	Buje	
	33	Y000 43928	1	Dado	Nut	Ecrou	Mutter	Tuerca	

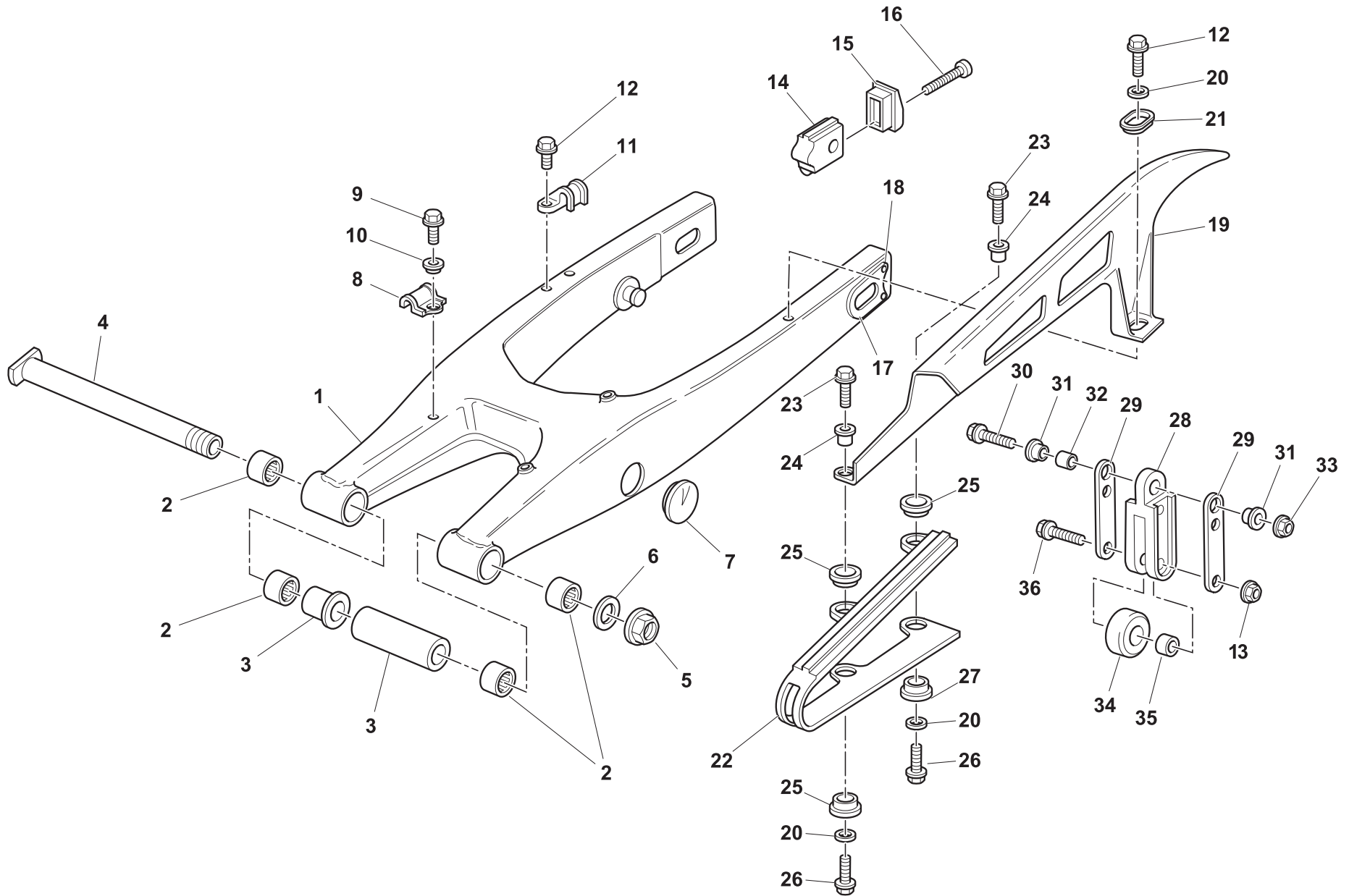

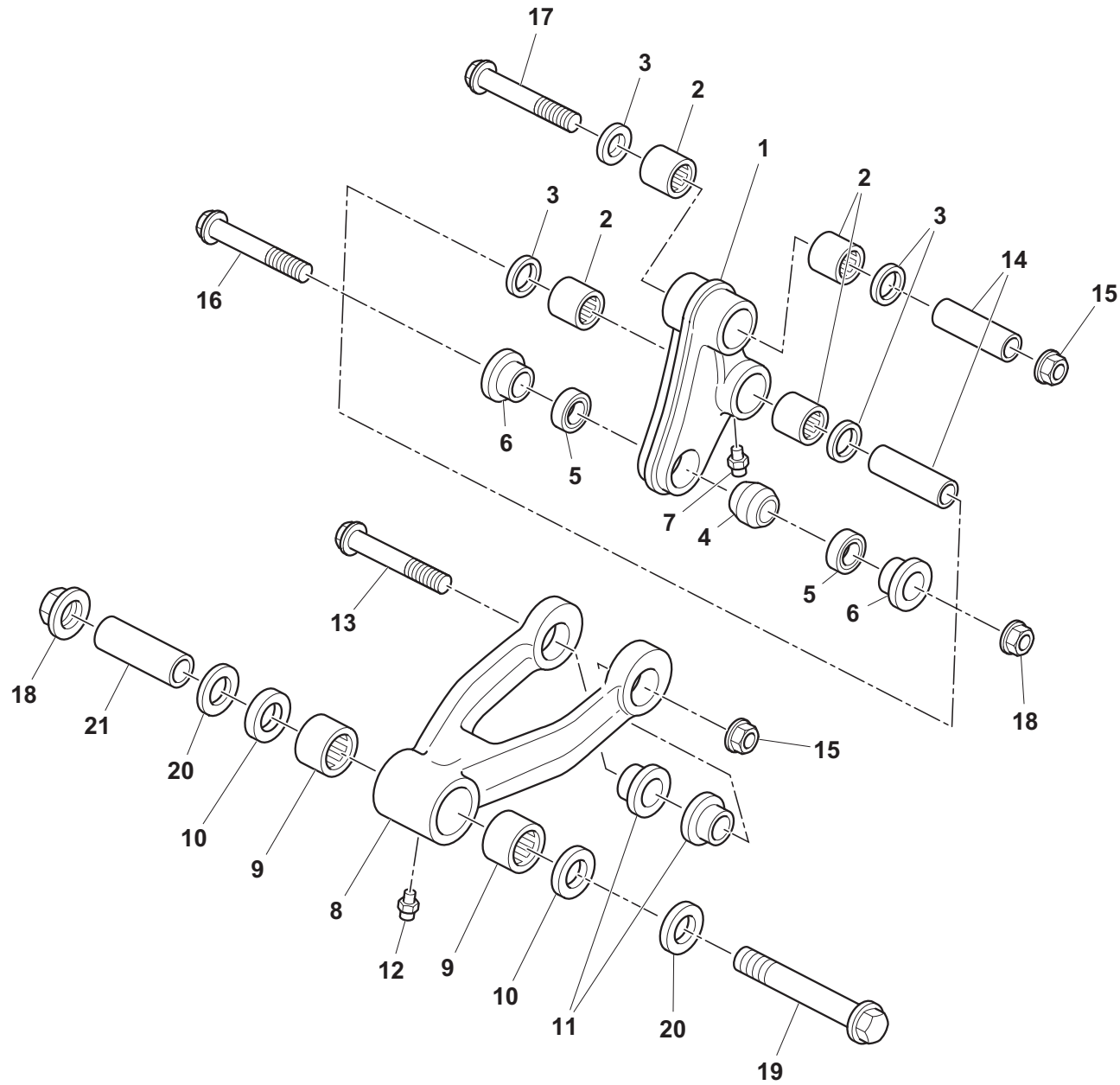



WRE 125 - SMS 125 / 2011

TAVOLA
DRAWING
TABLE
BILD
TABLA

16A

LEVERAGGI SOSPENSIONE POSTERIORE - REAR SUSPENSION LINKAGE
LEVIER SUSPENSION ARRIERE - HEBELWERK HINTERHAUFHANGUNG
PALANCA SUSPENSION TRASERA

Note Notes Notes Marke Notas	Pos. No. N. Index Pos.	N. Cod. Code No. Nr. Code Code Nr N. Cod.	Q.tà Q.ty Q.te M.ge C.ad	DENOMINAZIONE	NAME	DESIGNATION	BESHREIBUNG	DENOMINACION	Validità Validity Validité Gültig Validez
	1	8000 73348	1	Assieme bilanciare	Rocking lever assy	Balancier compl.	Schwinge Kpl.	Balancines compl.	
	2	8000 42781	4	Cuscinetto	Bearing	Roulement	Kugellager	Cojinete	
	3	8000 32065	4	Anello di tenuta	Seal ring	Bague d'étancheite	Dichtring	Anillo de retención	
	4	8000 72168	1	Cuscinetto sferico	Bearing	Roulement	Lager	Cojinete	
	5	8000 38767	2	Guarnizione	Gasket	Garniture	Dichtung	Junta	
	6	1511 33302	2	Bussola	Bushing	Douille	Buchse	Buje	
	7	8000 01412	1	Ingrassatore	Lubricator	Graisneur	Schmierbüchse	Lubricador	
	8	8D00 68157	1	Tirante completo	Tie rod	Tirant	Spannstange	Tirante	
	9	8000 38956	2	Boccola a rullini	Rollenbush	Douille rouleaux	Rollerbuchse	Buje	
	10	8000 38957	2	Anello di tenuta	Seal ring	Bague d'étancheite	Dichtring	Anillo de retención	
	11	8B00 42029	2	Bussola	Bushing	Douille	Buchse	Buje	
	12	8000 01412	1	Ingrassatore	Lubricator	Graisneur	Schmierbüchse	Lubricador	
	13	Y000 74372	2	Vite	Screw	Vis	Schraube	Tornillo	
	14	8A00 75153	2	Spinotto	Gudgeon	Axe	Bolzen	Perno	
	15	Z000 42023	2	Dado	Nut	Ecrou	Mutter	Tuerca	
	16	ZD00 62797	1	Vite	Screw	Vis	Schraube	Tornillo	
	17	YA00 74372	1	Vite	Screw	Vis	Schraube	Tornillo	
	18	Z000 42022	2	Dado	Nut	Ecrou	Mutter	Tuerca	
	19	ZA00 69138	1	Vite	Screw	Vis	Schraube	Tornillo	
	20	8000 73394	2	Anello di spugna	Ring	Bague	Ring	Anillo	
	21	8000 59839	1	Spinotto	Gudgeon	Axe	Bolzen	Perno	

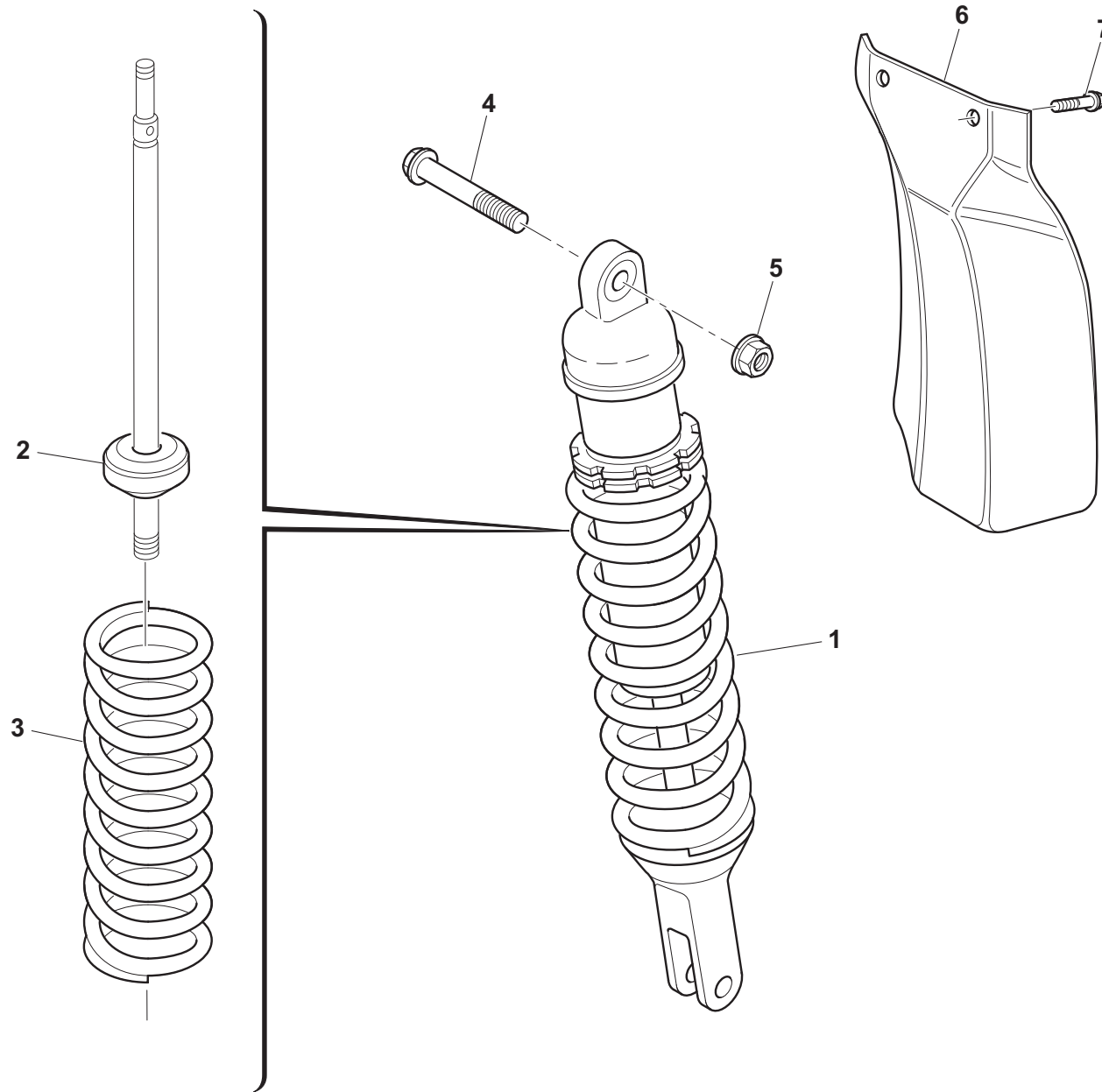

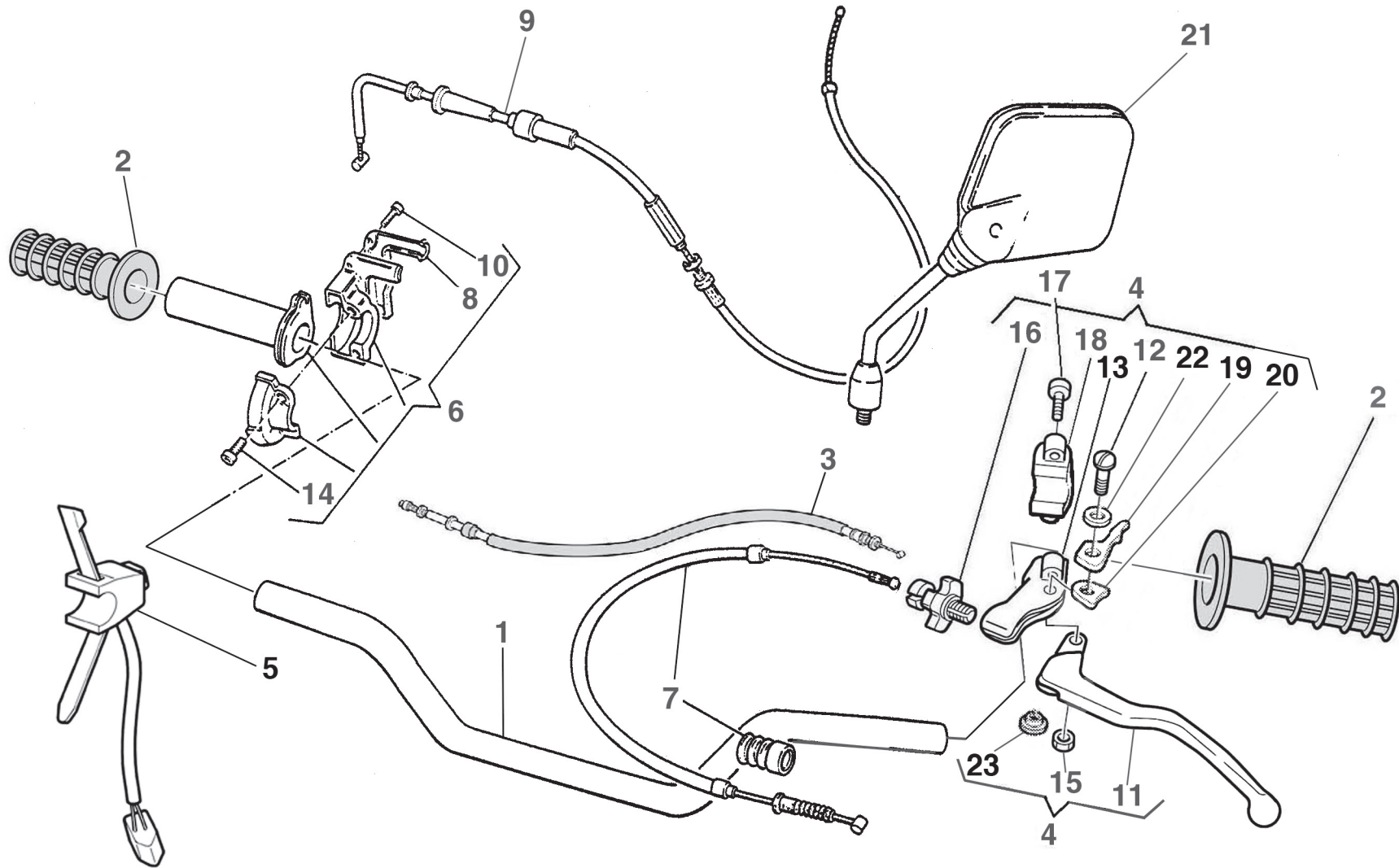



Note Notes Notes Marke Notas	Pos. No. N. Index Pos.	N. Cod. Code No. Nr. Code Code Nr N. Cod.	Q.tà Q.ty Q.te M.ge C.ad	DENOMINAZIONE	NAME	DESIGNATION	BESHREIBUNG	DENOMINACION	Validità Validity Validité Gültig Validez
	1	8000 H0044	1	Manubrio	Hanlebar	Guidon	Lenker	Manillar	
C	2	8000 H0995	1	Coppia manopole	Couple poignées	Grip pair	Griffpaar	Pareja manoplas	
	3	8000 A9204	1	Trasmissione starter	Starter wire	Transm. comm. starter	Anlassen Kabel	Transm. mando starter	
	4	8A00 87054	1	Com. frizione completo	Clutch trasm. assy	Trasm. embrayage compl.	Führungssteuerung	Mando embrague compl.	
	5	8000 A9753	1	Commutatore destro	R.H. switch	Commutateur droite	R. Kombischalter	Conmutador derecho	
	6	8000 75271	1	Comando gas completo	Throttle control compl.	Commande gaz compl.	Gasgriff kpl.	Accionam. acelerador com.	
	7	8000 A9205	1	Trasmissione com. frizione	Clutch transm.	Transm. com. embrayage	Führungssteuerung	Trans. mando embrague com.	
	8	8000 75310	1	Coperchietto	Cover	Couvercle	Deckel	Tapa	
	9	8000 A8762	1	Trasmissione gas	Throttle trasm.	Trasm. comm. gaz	Führungsteuerung des Gases	Tran.mando acelerador compl.	
	10	8000 66774	2	Vite	Screw	Vis	Schraube	Tornillo	
	11	8000 89813	1	Leva comando frizione	Clutch lever	Levier embrayage	Kupplungshebel	Palanca mando embrague	
	12	8000 89815	1	Vite	Screw	Vis	Schraube	Tornillo	
	13	8A00 88746	1	Supporto leva frizione	Clutch lever holder	Support levier embrayage	Kupplungshebelhalterung	Soporte palanca embregue	
	14	60N1 07330	2	Vite	Screw	Vis	Schraube	Tornillo	
	15	8000 61313	1	Dado	Nut	Ecrou	Mutter	Tuerca	
	16	8000 67355	1	Gruppo registro	Adjuster set	Groupe reglage	Kupplungsreglergruppe	Grupo regul.	
	17	Z000 62729	2	Vite	Screw	Vis	Schraube	Tornillo	
	18	8000 78915	1	Cavallotto	U-bolt	Cavalier	Bügelbolzen	Caballote	
	19	8000 47822	1	Leva aria	Starter control	Commande starter	Startergriff	Palanca arranque	
	20	8000 87276	1	Piastrina	Plate	Plaque	Platte	Placa	
D	21	8000 H1673	1	Specchio retrovisore compl.	Driving mirror	Rétroviseur	Rückspiegel	Espejo retrovisor	
	22	8000 47826	1	Rosetta	Washer	Rondelle	Scheibe	Arandela	
	23	8000 89814	1	Distanziale	Spacer	Entretoise	Distanzstück	Separador	

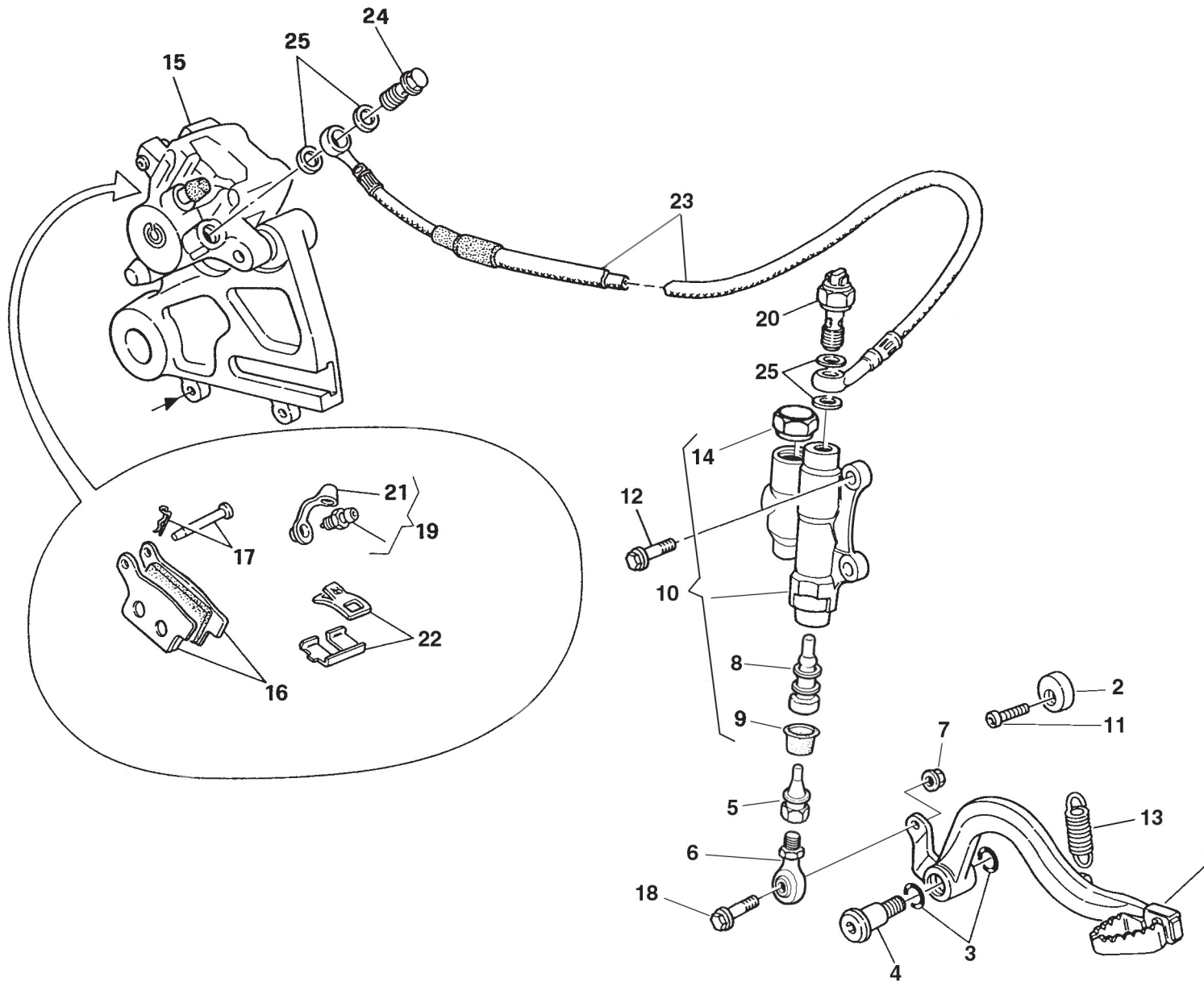



WRE 125 - SMS 125 / 2011

TAVOLA
DRAWING
TABLE
BILD
TABLA

18

FRENO IDRAULICO POSTERIORE - REAR HYDRAULIC BRAKE
FREIN HYDRAULIQUE ARRIERE - HINTERBREMSE
FRENO HIDRAULICO TRASERO

Note Notes Notes Marke Notas	Pos. No. N. Index Pos.	N. Cod. Code No. Nr. Code Code Nr N. Cod.	Q.tà Q.ty Q.te M.ge C.ad	DENOMINAZIONE	NAME	DESIGNATION	BESHREIBUNG	DENOMINACION	Validità Validity Validité Gültig Validez
	1	8000 H3866	1	Pedale comando freno	Brake control pedal	Pedal comm. frein	Bremspedal	Pedal accionamiento freno	
	2	8A00 69125	1	Camma	Cam	Came	Nocken	Exéntrico	
	3	8000 22551	2	Anello OR	O-Ring	Bague OR	O-Ring	Anillo OR	
	4	Y000 55902	1	Vite	Screw	Vis	Schraube	Tornillo	
	5	8000 A7635	1	Perno	Pin	Pivot	Bolzen	Perno	
	6	7640 10002	1	Snodo sferico	Ball joint	Joint a rotule	Kügelgelenk	Articulación esférica	
A	6	8A00 76055	1	Snodo sferico	Ball joint	Joint a rotule	Kügelgelenk	Articulación esférica	
	7	61ND 15062	1	Dado	Nut	Ecrou	Mutter	Tuerca	
	8	8000 A9448	1	Flottante	Plunger	Piston	Kolben	Pistón	
	9	8000 A9449	1	Cuffia	Boot	Poussier	Haube	Gorro	
	10	8000 A7633	1	Pompa freno	Brake pump	Pompe frein	Bremspumpe	Bomba freno	
	11	8000 55241	1	Vite	Screw	Vis	Schraube	Tornillo	
	12	ZH00 67545	2	Vite	Screw	Vis	Schraube	Tornillo	
	13	8000 55903	1	Molla	Spring	Ressort	Feder	Resorte	
	14	8000 A9447	1	Tappo	Plug	Bouchon	Verschlüss	Tapa	
	15	8000 76032	1	Pinza freno completa	Brake caliper assy	Pince de frein, compl.	Bremszange, Kpl.	Pinza freno compl.	
	16	8000 A9231	1	Coppia pastiglie	Pads pair	Paire plaquettes	Bremsbelagpaar	Pareja pastillas	
	17	8000 87152	1	Perno	Pin	Pivot	Bolzen	Perno	
	18	Z000 62727	1	Vite	Screw	Vis	Schraube	Tornillo	
	19	8000 60404	1	Spurgo	Spurgo	Drain	Entleerung	Purga	
	20	8000 94849	1	Interruttore stop posteriore	Stop switch	Interrupteur stop	Stopschalter	Interruptor stop	
	21	8000 53259	1	Parapolvere	Boots	Para-poudre	Schutzhaube	Para-polvo	
	22	8000 85932	1	Molla-lamierino	Spring-steel clip	Ressort	Feder	Rresorte	
	23	8000 78164	1	Tubo mandata olio	Pipe	Tuyau	Rohr	Tubo	
	24	8000 57155	1	Vite	Screw	Vis	Schraube	Tornillo	
	25	8000 21480	4	Rosetta ondulata	Washer	Rondelle	Scheibe	Arandela	

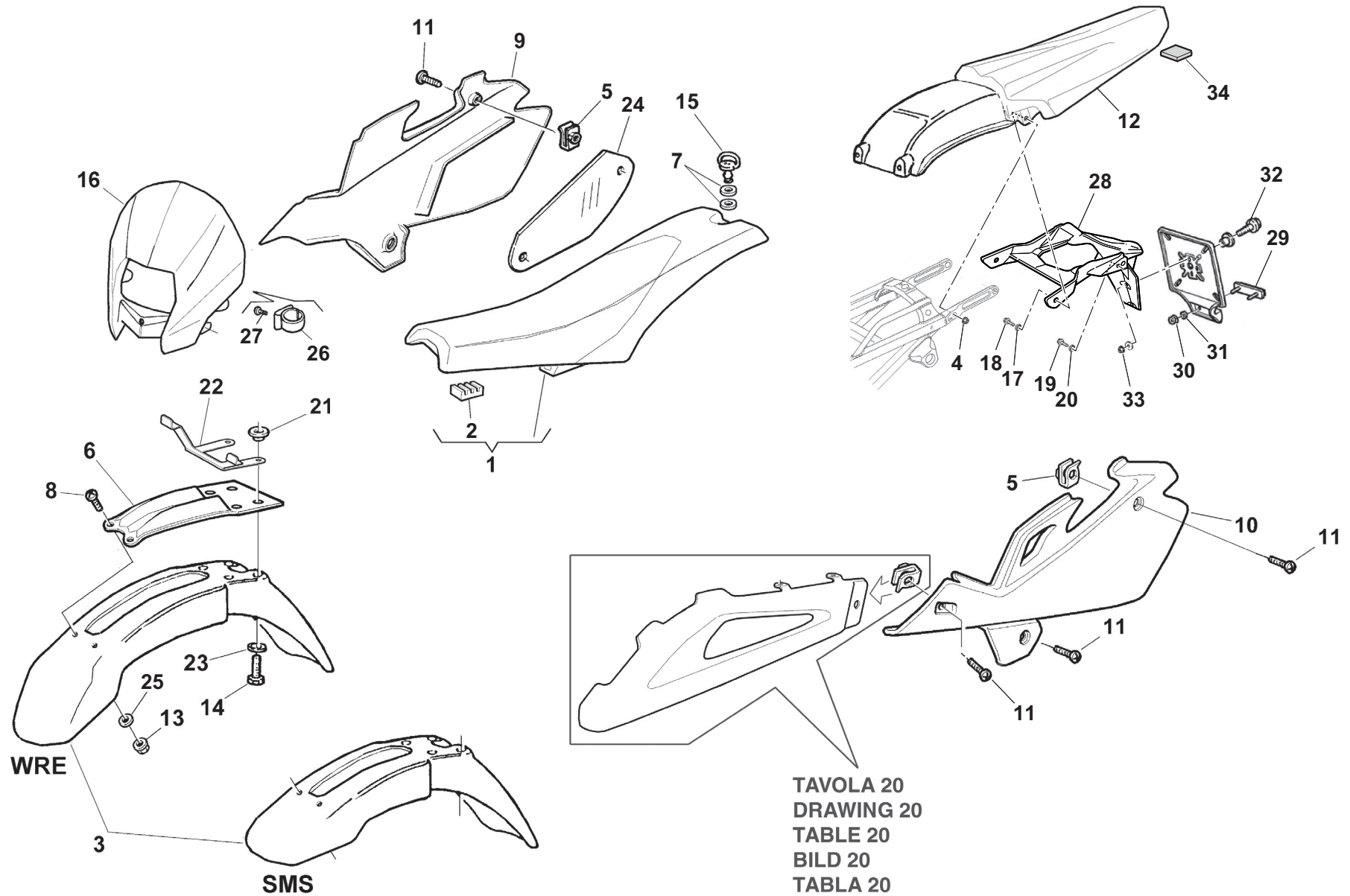



Note Notes Notes Marke Notas	Pos. No. N. Index Pos.	N. Cod. Code No. Nr. Code Code Nr N. Cod.	Q.tà Q.ty Q.te M.ge C.ad	DENOMINAZIONE	NAME	DESIGNATION	BESHREIBUNG	DENOMINACION	Validità Validity Validité Gültig Validez
	1	8000 A8792	1	Sella	Seat	Siège	Sattel	Sillín	
	2	8661 0191A	1	Tampone	Pad	Tampon	Stopfen	Tampón	
W	3	80C0 H0878	1	Parafango anteriore	Front mudguard	Garde-boue avant	Vord. Kotfluegel	Guarda-barros delantero	
M	3	8AC0 H0525	1	Parafango anteriore	Front mudguard	Garde-boue avant	Vord. Kotfluegel	Guarda-barros delantero	
	4	Z000 61313	2	Dado	Nut	Ecrou	Mutter	Tuerca	
	5	8000 55134	2	Dado a graffetta	Nut	Ecrou	Mutter	Tuerca	
W	6	80A0 A4198	1	Rinforzo parafango ant.	Front mudguard reinforcement	Renforcement garde-boue	Vord. Kotfluegel Verstärkung	Refuerzo guardabarros del.	
	7	8000 69149	2	Rosetta elastica	Spring washer	Rondelle élastique	Federscheibe	Arandela elástica	
	8	80A0 65535	2	Vite	Screw	Vis	Schraube	Tornillo	
W	9	8000 H3975	1	Pannello destro BIANCO/ROSSO	R.H. panel WHITE/RED	Panneau, D. BLANC/ROUGE	Streifen. R. WEISS/ROT	Panel derecho BLANCO/ROJO	
M	9	8000 H3975	1	Pannello destro BIANCO/ROSSO	R.H. panel WHITE/RED	Panneau, D. BLANC/ROUGE	Streifen. R. WEISS/ROT	Panel derecho BLANCO/ROJO	
M	9	8000 H5357	1	Pannello destro BIANCO/NERO	R.H. panel WHITE/BLACK	Panneau, D. BLANC/NOIR	Streifen. R. WEISS/SCHWARZ	Panel derecho BLANCO/NEGRO	
W	10	8000 H3976	1	Pannello sinistro BIANCO/ROSSO	L.H. panel WHITE/RED	Panneau, G. BLANC/ROUGE	Streifen. L. WEISS/ROT	Panel izquierdo BLANCO/ROJO	
M	10	8000 H3976	1	Pannello sinistro BIANCO/ROSSO	L.H. panel WHITE/RED	Panneau, G. BLANC/ROUGE	Streifen. L. WEISS/ROT	Panel izquierdo BLANCO/ROJO	
M	10	8000 H5358	1	Pannello sinistro BIANCO/NERO	L.H. panel WHITE/BLACK	Panneau, G. BLANC/NOIR	Streifen. L. WEISS/SCHWARZ	Panel izquierdo BLANCO/NEGRO	
	11	8B00 A8421	6	Vite (M5x16mm)	Screw (M5x16mm)	Vis (M5x16mm)	Schraube (M5x16mm)	Tornillo (M5x16mm)	
	12	8000 H5399	1	Parafango posteriore	Rear mudguard	Gardeboue arriere	Hint. Kotfluegel	Guarda-barros trasero	
	13	8000 61355	2	Dado	Nut	Ecrou	Mutter	Tuerca	
	14	8000 62729	4	Vite (M6x20mm)	Screw (M6x20mm)	Vis (M6x20mm)	Schraube (M6x20mm)	Tornillo (M6x20mm)	
	15	8000 H1917	1	Perno	Pin	Pivot	Bolzen	Perno	
	16	80C0 H0198	1	Cupolino	Fairing	Carenage	Verkleidung	Cúpula	
	17	8000 69429	2	Bussola	Bushing	Douille	Buchse	Manguito	
	18	Z000 62728	2	Vite (M6x25 mm)	Screw (M6x25 mm)	Vis (M6x25 mm)	Schraube (M6x25 mm)	Tornillo (M6x25 mm)	
	19	Z000 62728	2	Vite (M6x20 mm)	Screw (M6x20 mm)	Vis (M6x20 mm)	Schraube (M6x20 mm)	Tornillo (M6x20 mm)	
	20	8E00 69429	2	Bussola	Bushing	Douille	Buchse	Manguito	
	21	8C00 69429	4	Bussola	Bushing	Douille	Buchse	Casquillo	
	22	8000 H3006	4	Fissaggio inf. Portanumero	Number holder lower fix.	Fixage inf. porte nombre	Untere befestigung Nummertrager	Fijación inf. porta numero	
	23	8000 48814	4	Rosetta	Washer	Rondelle	Scheibe	Arandela	
	24	8000 A4875	1	Protezione	Guard	Protection	Schutz	Protección	
	25	62ND 15548	2	Rosetta	Washer	Rondelle	Scheibe	Arandela	
	26	8000 A0864	1	Anello	Ring	Anneau	Ring	Anillo	
	27	ZA00 37283	2	Vite	Screw	Vis	Schraube	Tornillo	
	28	8000 H1405	1	Supporto targa	License plate bracket	Support plaque	Nummernschildträger	Soporte placa porta matrícula	

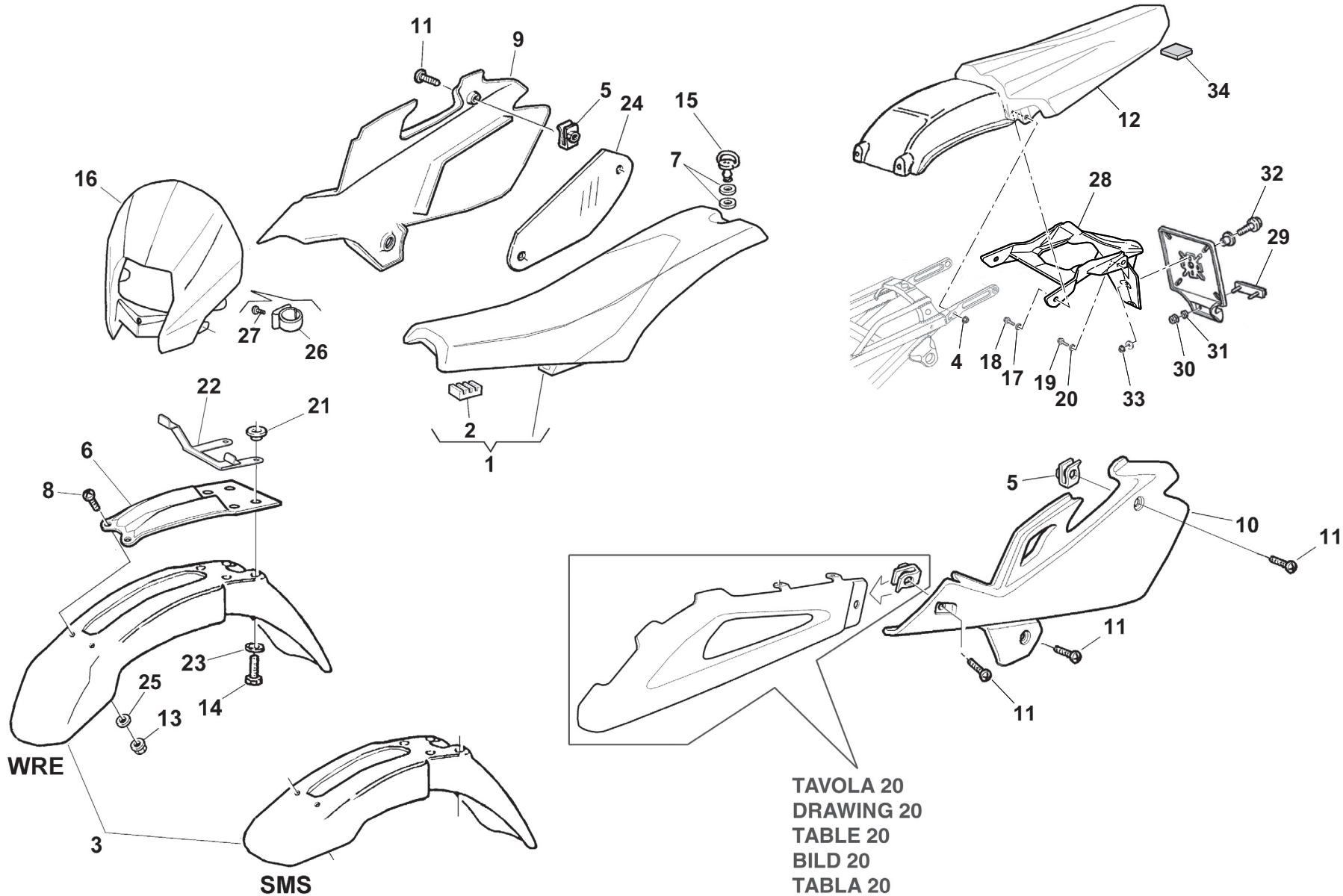



TAVOLA 20
DRAWING 20
TABLE 20
BILD 20
TABLA 20



SMS 125 / 2011

TAVOLA
DRAWING
TABLE
BILD
TABLA

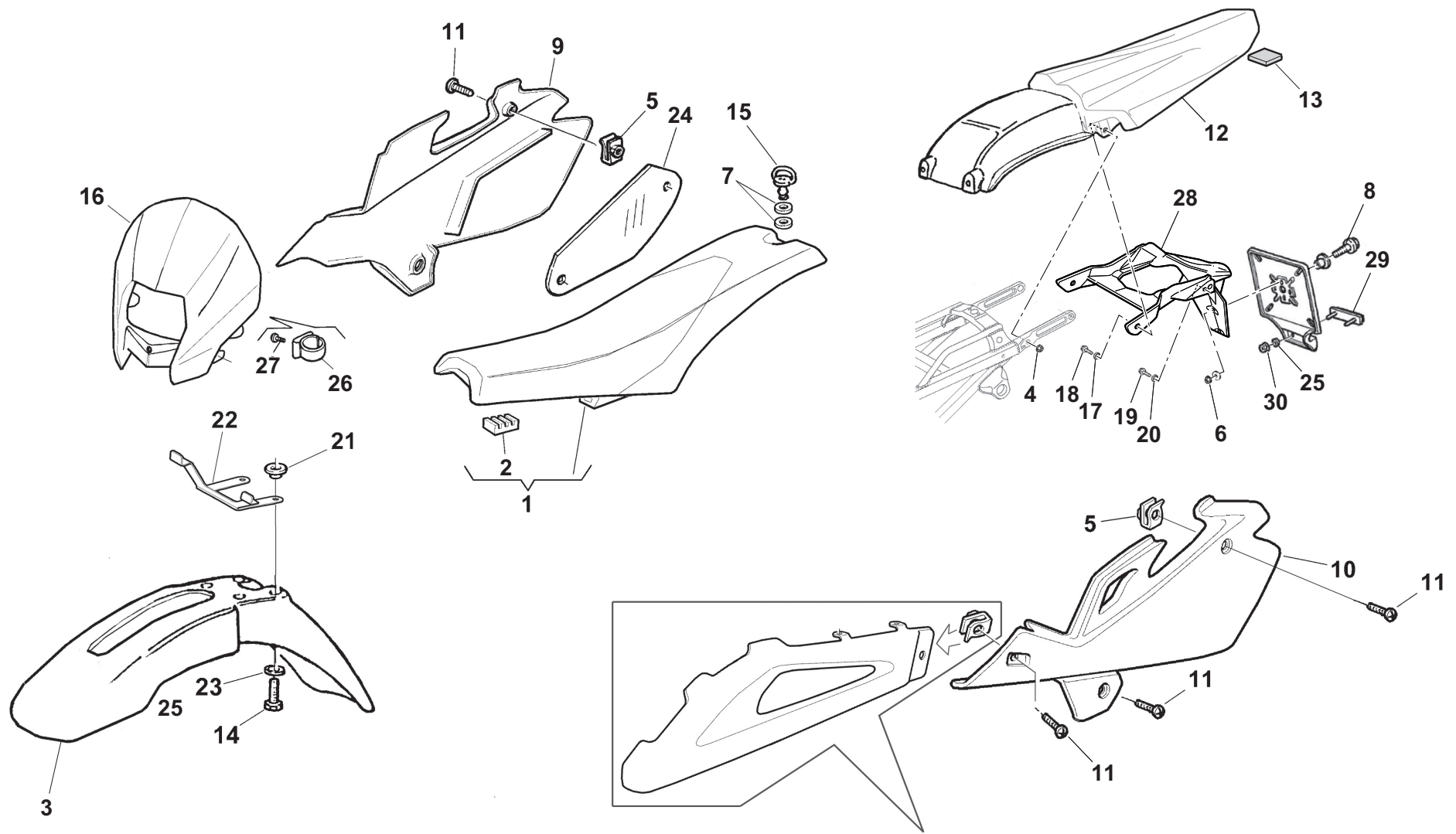
19A

PANNELLI LATERALI, PARAFANGHI, SELLA HERMUNEN - SIDE PANEL, FENDERS, SEAT HERMUNEN
PANNEAU, GARDE-BOUES, SIEGE HERMUNEN - STREIFEN, KOTFLUGEL, SATTEL HERMUNEN
PANELES, GUARDABARROS, SILLIN HERMUNEN

Note Notes Notes Marke Notas	Pos. No. N. Index Pos.	N. Cod. Code No. Nr. Code Code Nr N. Cod.	Q.tà Q.ty Q.te M.ge C.ad	DENOMINAZIONE	NAME	DESIGNATION	BESHREIBUNG	DENOMINACION	Validità Validity Validité Gültig Validez
	1	8000 A8792	1	Sella	Seat	Siège	Sattel	Sillín	
	2	8661 0191A	1	Tampone	Pad	Tampon	Stopfen	Tampón	
	3	8AC0 H0525	1	Parafango anteriore	Front mudguard	Garde-boue avant	Vord. Kotfluegel	Guarda-barros delantero	
	4	Z000 61313	2	Dado	Nut	Ecrou	Mutter	Tuerca	
	5	8000 55134	2	Dado a graffetta	Nut	Ecrou	Mutter	Tuerca	
	6	Z000 44240	2	Dado	Nut	Ecrou	Mutter	Tuerca	
	7	8000 69149	2	Rosetta elastica	Spring washer	Rondelle élastique	Federscheibe	Arandela elástica	
	8	Z000 62727	2	Vite (M6x16 mm)	Screw (M6x16 mm)	Vis (M6x16 mm)	Schraube (M6x16 mm)	Tornillo (M6x16 mm)	
	9	8000 H6305	1	Pannello destro	R.H. panel	Panneau, D.	Streifen. R.	Panel derecho	
	10	8000 H6306	1	Pannello sinistro	L.H. panel	Panneau, G.	Streifen. L.	Panel izquierdo	
	11	8B00 A8421	6	Vite (M5x16mm)	Screw (M5x16mm)	Vis (M5x16mm)	Schraube (M5x16mm)	Tornillo (M5x16mm)	
	12	8000 H5399	1	Parafango posteriore	Rear mudguard	Gardeboue arriere	Hint. Kotfluegel	Guarda-barros trasero	
	13	8000 86004	1	Antivibrante adesivo	Silent-Hock	Antivibration	Schwingungsdämpfen	Anti-vibrador	
	14	8000 62729	4	Vite (M6x20mm)	Screw (M6x20mm)	Vis (M6x20mm)	Schraube (M6x20mm)	Tornillo (M6x20mm)	
	15	8000 H1917	1	Perno	Pin	Pivot	Bolzen	Perno	
	16	80C0 H0198	1	Cupolino	Fairing	Carenage	Verkleidung	Cúpula	
	17	8000 69429	2	Bussola	Bushing	Douille	Buchse	Manguito	
	18	Z000 62728	2	Vite (M6x25 mm)	Screw (M6x25 mm)	Vis (M6x25 mm)	Schraube (M6x25 mm)	Tornillo (M6x25 mm)	
	19	Z000 62728	2	Vite (M6x20 mm)	Screw (M6x20 mm)	Vis (M6x20 mm)	Schraube (M6x20 mm)	Tornillo (M6x20 mm)	
	20	8E00 69429	2	Bussola	Bushing	Douille	Buchse	Manguito	
	21	8C00 69429	4	Bussola	Bushing	Douille	Buchse	Casquillo	
	22	8000 H3006	4	Fissaggio inf. Portanumero	Number holder lower fix.	Fixage inf. porte nombre	Untere befestigung Nummertrager	Fijación inf. porta numero	
	23	8000 48814	4	Rosetta	Washer	Rondelle	Scheibe	Arandela	
	24	8000 A4875	1	Protezione	Guard	Protection	Schutz	Protección	
	25	62ND 15547	2	Rosetta	Washer	Rondelle	Scheibe	Arandela	
	26	8000 A0864	1	Anello	Ring	Anneau	Ring	Anillo	
	27	ZA00 37283	2	Vite	Screw	Vis	Schraube	Tornillo	
	28	8000 H1405	1	Supporto targa	License plate bracket	Support plaque	Nummernschildträger	Soporte placa porta matrícula	
	29	8000 73834	1	Catadiottro	Reflector	Catadioptrique	Ruckstrahler	Catafaros	
	30	Z000 40717	2	Dado	Nut	Ecrou	Mutter	Tuerca	

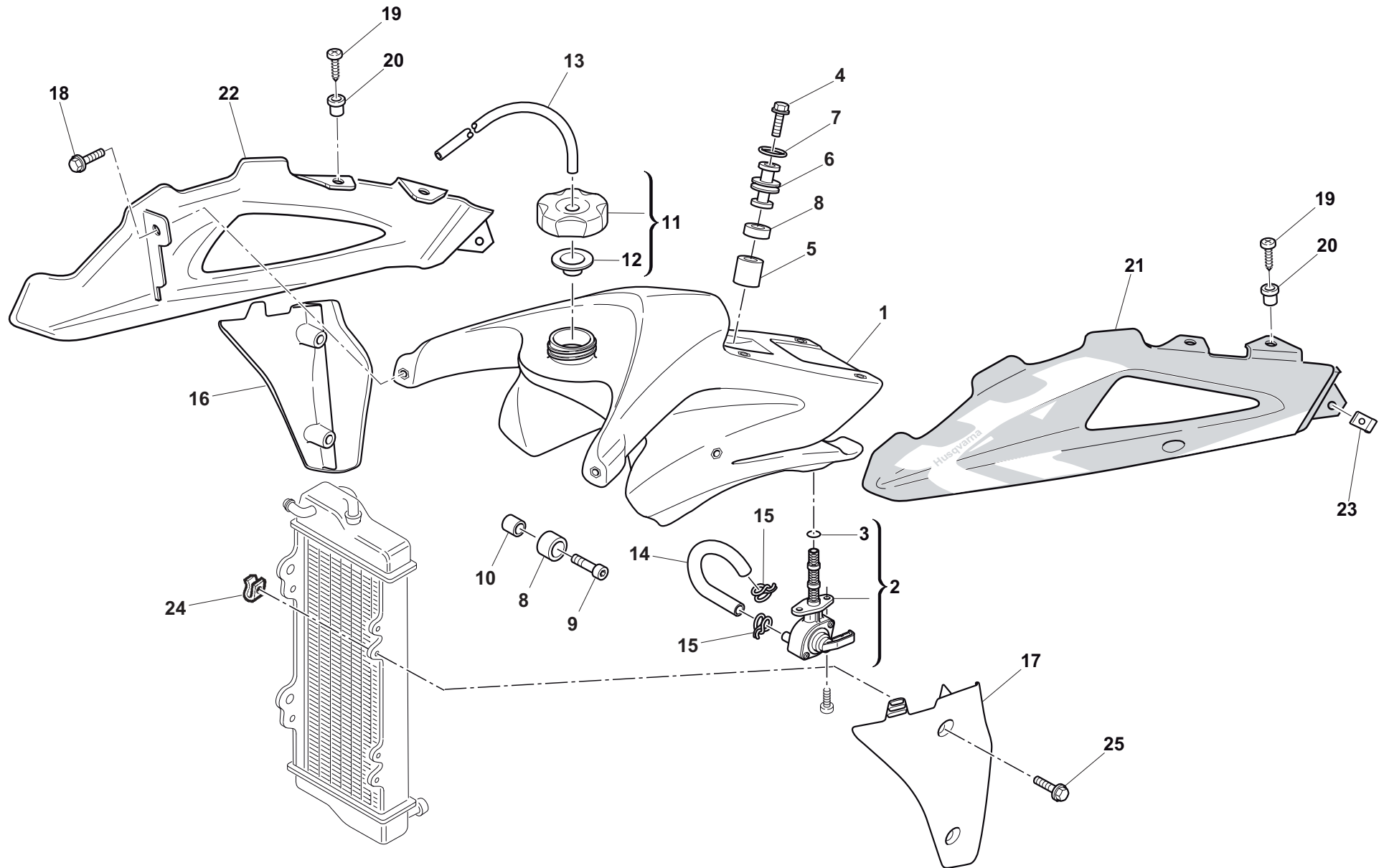



Note Notes Marke Notas	Pos. No. N. Index Pos.	N. Cod. Code No. Nr. Code Code Nr N. Cod.	Q.tà Q.ty Q.te M.ge C.ad	DENOMINAZIONE	NAME	DESIGNATION	BESHREIBUNG	DENOMINACION	Validità Validity Validité Gültig Validez
	1	80A0 A5507	1	Serbatoio carburante (l 9,5)	Fuel tank (l 9,5)	Réservoir essence (l 9,5)	Kraftstoffbehälter (l 9,5)	Depósito gasolina (l 9,5)	
	2	8000 H4503	1	Rubinetto completo	Cock assy	Robinet compl.	Kraftstoffahn, Kpl.	Llave de paso compl.	
	3	8000 H4520	1	Anello OR	O-Ring	Bague OR	O Ring	Anillo OR	
	4	ZJ00 67545	1	Vite	Screw	Vis	Schraube	Tornillo	
	5	8000 A8040	1	Distanziale	Spacer	Entretoise	Distanzstück	Separador	
	6	8B00 A0702	1	Distanziale (46 mm)	Spacer (46 mm)	Entretoise (46 mm)	Distanzstück (46 mm)	Separador (46 mm)	
	7	8000 28929	1	Anello OR	O-Ring	Bague OR	O Ring	Anillo OR	
	8	8000 A0528	3	Tampone	Pad	Tampon	Stopfen	Tampón	
	9	60ND 02510	2	Vite	Screw	Vis	Schraube	Tornillo	
	10	8000 A0680	2	Distanziale	Spacer	Entretoise	Distanzstück	Separador	
	11	8000 B1057	1	Tappo serbatoio	Tank cap	Bouchon reservoir	Behälterstöpsel	Tapón depósito	
	12	8000 A4562	1	Guarnizione	Gasket	Garniture	Dichtung	Junta	
	13	8T00 68873	1	Condotto sfiato (L=300 mm)	Breather line (L=300 mm)	Conduite purge (L=300 mm)	Entlueftungsleitung (L=300 mm)	Tuberia purga de aire (L=300 mm)	
	14	8000 H4027	1	Condotto benzina (L=205 mm)	Hose (L=205 mm)	Tuyau (L=205 mm)	Rohr (L=205 mm)	Tubo (L=205 mm)	
	15	80A0 42349	2	Fascetta	Clamp	Collier	Schelle	Banda	
	16	80A0 A5978	1	Protezione Dx	R.H. guard	Protection D.	Schutz Rechte	Protección derecha	
	17	80A0 A5977	1	Protezione Sx	L.H. guard	Protection G.	Schutz Linke	Protección izquierda	
	18	8000 A8423	2	Vite (M6x8 mm)	Screw (M6x8 mm)	Vis (M6x8 mm)	Schraube (M6x8mm)	Tornillo (M6x8 mm)	
	19	Z000 36467	4	Vite (M6x10 mm)	Screw (M6x10 mm)	Vis (M6x10 mm)	Schraube (M6x10 mm)	Tornillo (M6x10 mm)	
	20	8000 H3017	4	Bussola	Bushing	Douille	Buchse	Manguito	
W	21	8000 H3977	1	Conv. SX - ROSSO	L. panel - RED	Flanc G. - ROUGE	Flanke L. - ROT	Lateral I. - ROJO	
M	21	8000 H3977	1	Conv. SX - ROSSO	L. panel - RED	Flanc G. - ROUGE	Flanke L. - ROT	Lateral I. - ROJO	
M	21	8000 H5359	1	Conv. SX - NERO	L. panel - BLACK	Flanc G. - NOIR	Flanke L. - SCHWARZ	Lateral I. - NEGRO	
W	22	8000 H3978	1	Conv. DX - ROSSO	R. panel - RED	Flanc D. - ROUGE	Flanke R. - ROT	Lateral D. - ROJO	
M	22	8000 H3978	1	Conv. DX - ROSSO	R. panel - RED	Flanc D. - ROUGE	Flanke R. - ROT	Lateral D. - ROJO	
M	22	8000 H5360	1	Conv. DX - NERO	R. panel - BLACK	Flanc D. - NOIR	Flanke R. - SCHWARZ	Lateral D. - NEGRO	
	23	U000 55134	2	Dado a graffetta	Nut	Ecrou	Mutter	Tuerca	
	24	U000 60873	2	Dado a graffetta	Nut	Ecrou	Mutter	Tuerca	
	25	8A00 A8423	4	Vite (M6x12 mm)	Screw (M6x12 mm)	Vis (M6x12 mm)	Schraube (M6x12 mm)	Tornillo (M6x12 mm)	

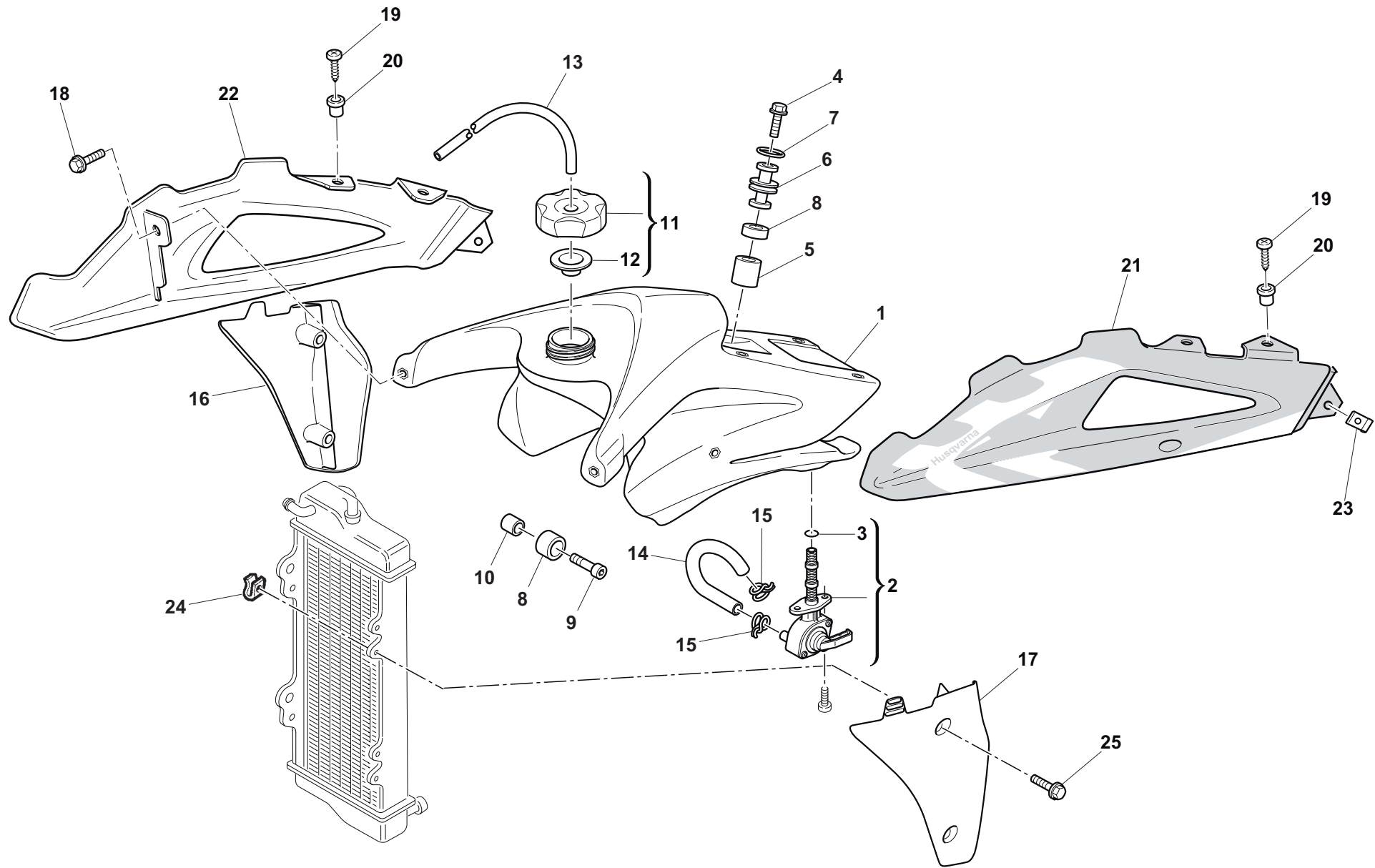



SMS 125 / 2011

TAVOLA
DRAWING
TABLE
BILD
TABLA

20A

SERBATOIO/ CONVOGLIATORI HERMUNEN - GAS TANK/ PANEL HERMUNEN
RESERVOIR/ FLANC HERMUNEN - KRAFTSTOFFBEHALTER/ FLANKE HERMUNEN
DEPOSITO/ LATERAL HERMUNEN

Note Notes Notes Marke Notas	Pos. No. N. Index Pos.	N. Cod. Code No. Nr. Code Code Nr N. Cod.	Q.tà Q.ty Q.te M.ge C.ad	DENOMINAZIONE	NAME	DESIGNATION	BESHREIBUNG	DENOMINACION	Validità Validity Validité Gültig Validez
	1	80A0 A5507	1	Serbatoio carburante (l 9,5)	Fuel tank (l 9,5)	Réservoir essence (l 9,5)	Kraftstoffbehälter (l 9,5)	Depósito gasolina (l 9,5)	
	2	8000 H4503	1	Rubinetto completo	Cock assy	Robinet compl.	Kraftstoffahn, Kpl.	Llave de paso compl.	
	3	8000 H4520	1	Anello OR	O-Ring	Bague OR	O Ring	Anillo OR	
	4	ZJ00 67545	1	Vite	Screw	Vis	Schraube	Tornillo	
	5	8000 A8040	1	Distanziale	Spacer	Entretoise	Distanzstück	Separador	
	6	8B00 A0702	1	Distanziale (46 mm)	Spacer (46 mm)	Entretoise (46 mm)	Distanzstück (46 mm)	Separador (46 mm)	
	7	8000 28929	1	Anello OR	O-Ring	Bague OR	O Ring	Anillo OR	
	8	8000 A0528	3	Tampone	Pad	Tampon	Stopfen	Tampón	
	9	60ND 02510	2	Vite	Screw	Vis	Schraube	Tornillo	
	10	8000 A0680	2	Distanziale	Spacer	Entretoise	Distanzstück	Separador	
	11	8000 B1057	1	Tappo serbatoio	Tank cap	Bouchon reservoir	Behälterstöpsel	Tapón depósito	
	12	8000 A4562	1	Guarnizione	Gasket	Garniture	Dichtung	Junta	
	13	8T00 68873	1	Condotto sfiato (L=300 mm)	Breather line (L=300 mm)	Conduite purge (L=300 mm)	Entlueftungsleitung (L=300 mm)	Tuberia purga de aire (L=300 mm)	
	14	8000 H4027	1	Condotto benzina (L=205 mm)	Hose (L=205 mm)	Tuyau (L=205 mm)	Rohr (L=205 mm)	Tube (L=205 mm)	
	15	80A0 42349	2	Fascetta	Clamp	Collier	Schelle	Banda	
	16	80A0 A5978	1	Protezione Dx	R.H. guard	Protection D.	Schutz Rechte	Protección derecha	
	17	80A0 A5977	1	Protezione Sx	L.H. guard	Protection G.	Schutz Linke	Protección izquierda	
	18	8000 A8423	2	Vite (M6x8 mm)	Screw (M6x8 mm)	Vis (M6x8 mm)	Schraube (M6x8mm)	Tornillo (M6x8 mm)	
	19	Z000 36467	4	Vite (M6x10 mm)	Screw (M6x10 mm)	Vis (M6x10 mm)	Schraube (M6x10 mm)	Tornillo (M6x10 mm)	
	20	8000 H3017	4	Bussola	Bushing	Douille	Buchse	Manguito	
	21	8000 H3977	1	Conv. SX - ROSSO	L. panel - RED	Flanc G. - ROUGE	Flanke L. - ROT	Lateral I. - ROJO	
	22	8000 H3978	1	Conv. DX - ROSSO	R. panel - RED	Flanc D. - ROUGE	Flanke R. - ROT	Lateral D. - ROJO	
	23	U000 55134	2	Dado a graffetta	Nut	Ecrou	Mutter	Tuerca	
	24	U000 60873	2	Dado a graffetta	Nut	Ecrou	Mutter	Tuerca	
	25	8A00 A8423	4	Vite (M6x12 mm)	Screw (M6x12 mm)	Vis (M6x12 mm)	Schraube (M6x12 mm)	Tornillo (M6x12 mm)	

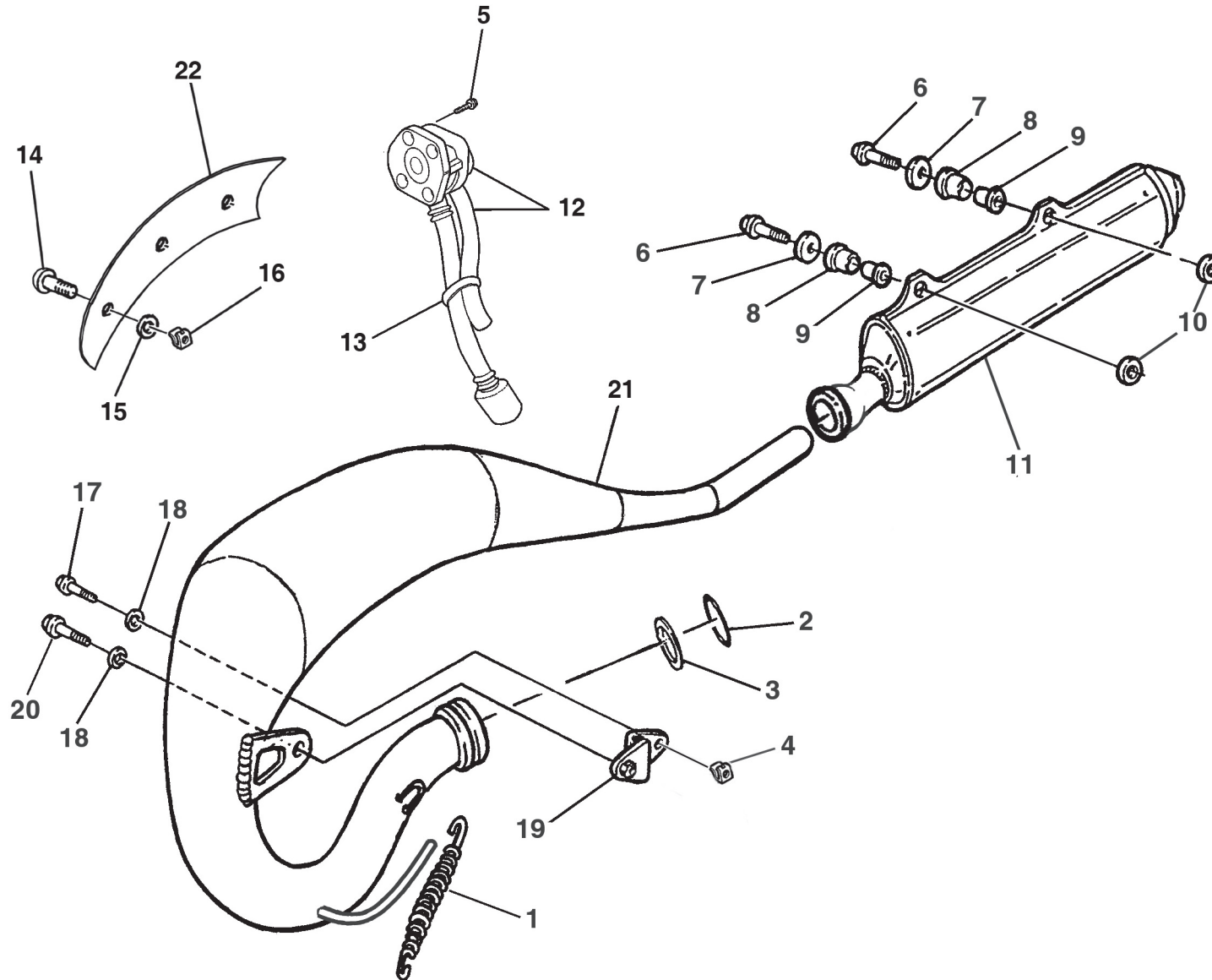



WRE 125 - SMS 125 / 2011

TAVOLA
DRAWING
TABLE
BILD
TABLA

21

SCARICO - EXHAUST SYSTEM
TUYAU D'ÉCHAPPEMENT - AUSPUFFROHR
TUBO DE ESCAPE

Note Notes Notes Marke Notas	Pos. No. N. Index Pos.	N. Cod. Code No. Nr. Code Code Nr N. Cod.	Q.tà Q.ty Q.te M.ge C.ad	DENOMINAZIONE	NAME	DESIGNATION	BESHREIBUNG	DENOMINACION	Validità Validity Validité Gültig Validez
	1	8000 H3011	2	Molla	Spring	Ressort	Feder	Resorte	
	2	8A00 23186	1	Anello OR	O-Ring	Bague OR	O-Ring	Anillo OR	
	3	8000 H3020	1	Rosetta	Washer	Rondelle	Scheibe	Arandela	
	4	U000 46893	1	Dado	Nut	Ecrou	Mutter	Tuerca	
	5	60ND 02483	2	Vite	Screw	Vis	Schraube	Tornillo	
	6	ZA00 67545	2	Vite	Screw	Vis	Schraube	Tornillo	
	7	1513 74301	2	Rosetta	Washer	Rondelle	Scheibe	Arandela	
	8	1514 10702	2	Gommino	Rubber pad	Pièce caoutchouc	Gummistück	Junta de goma	
	9	8B00 70379	2	Distanziale	Spacer	Entretoise	Distanzstück	Separador	
	10	1513 41401	2	Gommino	Rubber pad	Pièce caoutchouc	Gummistück	Junta de goma	
	11	8B00 94808	1	Silenziatore	Exhaust silencer	Silencieux d'éch.	Schalldämpfer	Silenciador	
	12	8000 A6090	1	Valvola aria secondaria	Secondary air valve	Soupape air secondaire	Secondäres Luftventil	Válvula aire secundario	
	13	8000 56444	1	Fascetta (L=188mm)	Clamp (L=188mm)	Collier (L=188mm)	Schelle (L=188mm)	Banda (L=188mm)	
	14	Z000 36467	3	Vite	Screw	Vis	Schraube	Tornillo	
	15	8000 35112	3	Rosetta	Washer	Rondelle	Scheibe	Arandela	
	16	U000 46893	3	Dado	Nut	Ecrou	Mutter	Tuerca	
	17	Z000 62727	1	Vite	Screw	Vis	Schraube	Tornillo	
	18	8000 45499	2	Rosetta piana	Washer	Rondelle	Scheibe	Arandela	
	19	8000 69113	1	Antivibrante	Silent-block	Antivibration	Schwingungsdämpfer	Anti-vibrador	
	20	Z000 62726	1	Vite	Screw	Vis	Schraube	Tornillo	
	21	8000 H1376	1	Tubo di scarico	Exhaust pipe	Tuyau d'échapp.	Auspuffrohr	Tubo de escape	
U	21	8000 H6326	1	Tubo di scarico	Exhaust pipe	Tuyau d'échapp.	Auspuffrohr	Tubo de escape	
	22	8000 H1378	1	Protezione calore	Guard	Protection	Schutz	Protección	

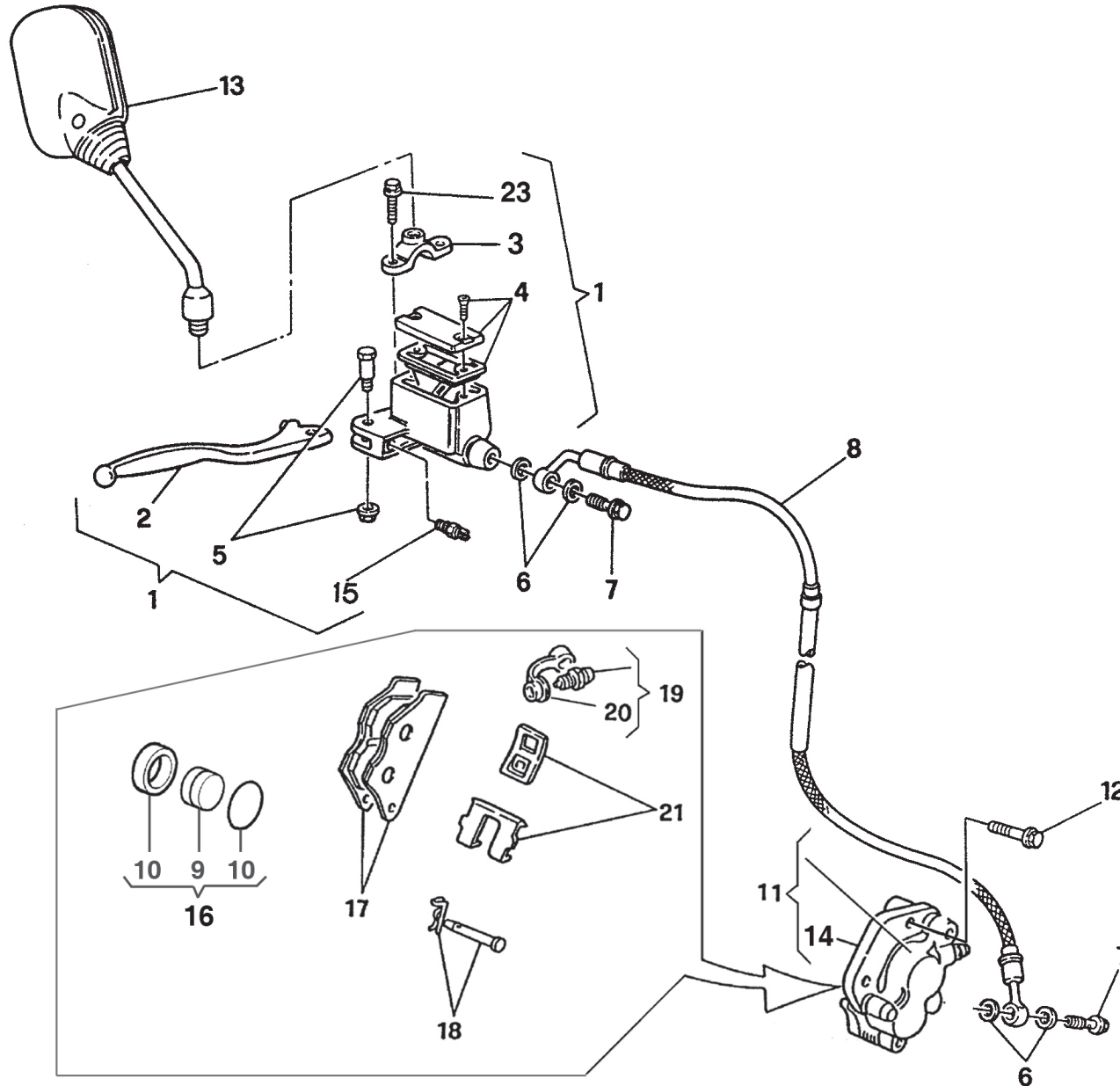



WRE 125 - SMS 125 / 2011

TAVOLA
DRAWING
TABLE
BILD
TABLA

22

FRENO IDRAULICO ANTERIORE - FRONTHYDRAULIC BRAKE
FREIN HYDRAULIQUE AVANT - VORTERBREMSE
FRENO HIDRAULICO DELANTERA

Note Notes Marke Notas	Pos. No. N. Index Pos.	N. Cod. Code No. Nr. Code Code Nr N. Cod.	Q.tà Q.ty Q.te M.ge C.ad	DENOMINAZIONE	NAME	DESIGNATION	BESHREIBUNG	DENOMINACION	Validità Validity Validité Gültig Validez
	1	8A00 76024	1	Pompa comando freno ant.	Brake pump	Pompe frein	Bremspumpe	Bomba freno	
	2	8000 79067	1	Leva	Lever	Levier	Hebel	Palanca	
	3	8000 79068	1	Cavallotto	U-bolt	Cavalier	Bügelbolzen	Caballete	
	4	8000 79069	1	Kit tappo	Plug kit	Bouchon kit	Verschluss Gruppe	Kit tapón	
	5	8000 79070	1	Perno	Pin	Pivot	Bolzen	Perno	
	6	8000 21480	4	Rosetta	Washer	Rondelle	Scheibe	Arandela	
	7	U000 57155	2	Vite	Screw	Vis	Schraube	Tornillo	
	8	8B00 76025	1	Tubo mandata olio	Pipe	Tuyau	Rohr	Tubo	
	9	8000 A1138	1	Pistone	Piston	Piston	Kolben	Pistón	
	10	8000 A1139	1	Guarnizioni	Packing	Joint	Dichtung	Junta	
W	11	8000 99674	1	Pinza freno	Brake caliper	Etrier frein	Bremssattel	Pinza	
M	11	8000 H4180	1	Pinza freno	Brake caliper	Etrier frein	Bremssattel	Pinza	
	12	ZK00 69056	2	Vite	Screw	Vis	Schraube	Tornillo	
D	13	8A00 H1673	1	Specchio retrovisore compl.	Driving mirror	Rétroviseur	Ruckspiegel	Espejo retrovisor	
	14	8000 99859	1	Supporto	Holder	Support	Halterung	Soporte	
	15	8000 H2099	1	Interruttore stop	Stop switch	Interrupteur stop	Stopschalter	Interruptor stop	
	16	8000 A0930	1	Pistone completo	Piston, assy.	Piston complet	Kolben, kpl.	Pistón compl.	
W	17	8000 96934	1	Coppia pastiglie	Pads pair	Paire plaquettes	Bremsbelagpaar	Pareja pastillas	
M	17	8000 H4701	1	Coppia pastiglie	Pads pair	Paire plaquettes	Bremsbelagpaar	Pareja pastillas	
	18	8000 A0932	1	Perno	Pin	Pivot	Bolzen	Perno	
	19	8000 A0931	1	Spurgo	Spurgo	Drain	Entleerung	Purga	
	20	8000 53259	1	Parapolvere	Boots	Para-poudre	Schutzhaube	Para-polvo	
	21	8000 79065	1	Molla-lamierino	Spring-steel clip	Ressort	Feder	Rresorte	
	22	8000 79066	1	Cuffie	Boots	Poussiers	Haube	Gorro	
	23	8000 62729	2	Vite	Screw	Vis	Schraube	Tornillo	

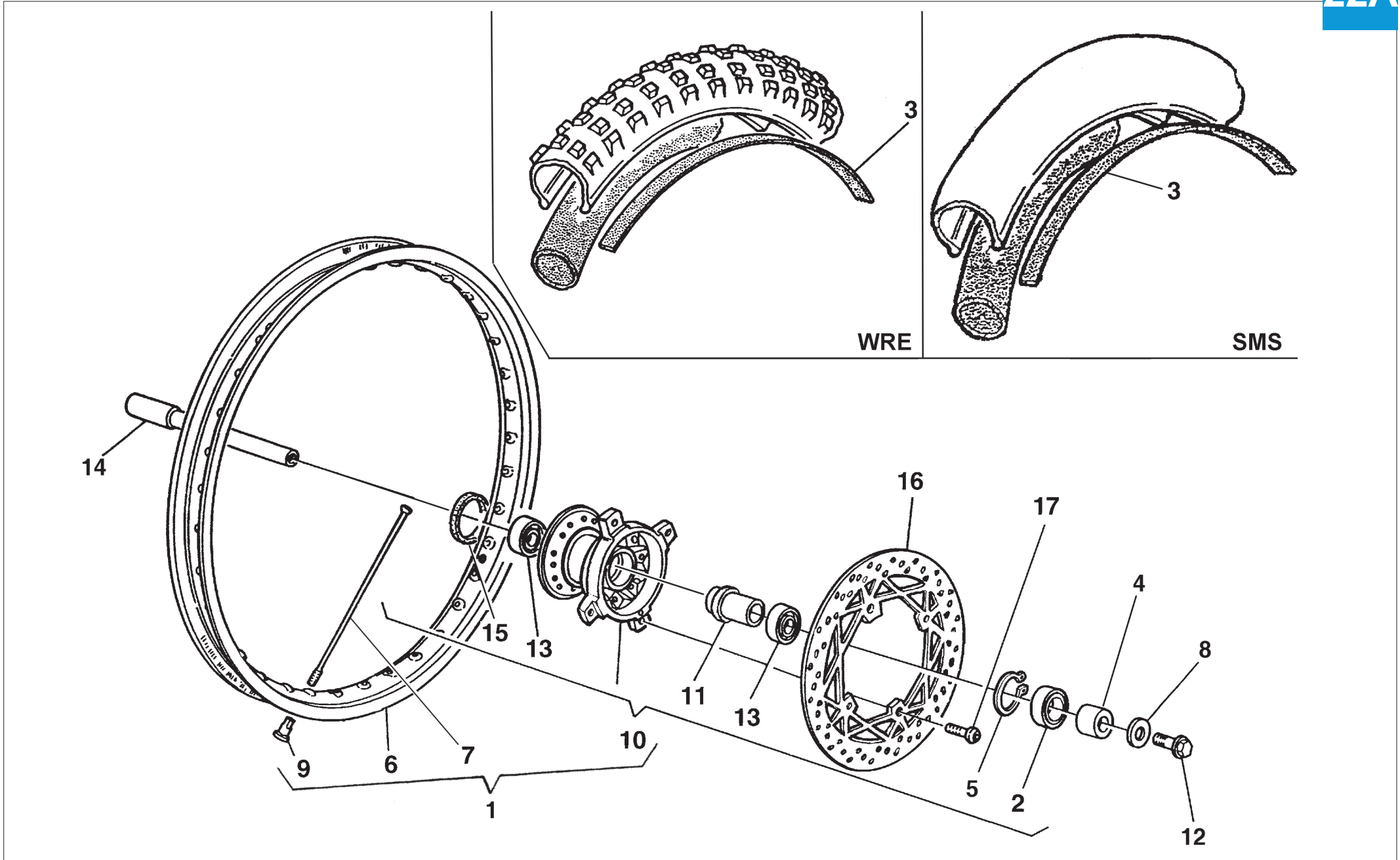



WRE 125 - SMS 125 / 2011

TAVOLA
DRAWING
TABLE
BILD
TABLA

22A

RUOTA ANTERIORE - FRONT WHEEL
ROUE AVANT - VORTERRAD
RUEDA DELANTERA

Note Notes Marke Notas	Pos. No. N. Index Pos.	N. Cod. Code No. Nr. Code Code Nr N. Cod.	Q.tà Q.ty Q.te M.ge C.ad	DENOMINAZIONE	NAME	DESIGNATION	BESHREIBUNG	DENOMINACION	Validità Validity Gültig Validez
W	1	8000 H6389	1	Ruota anteriore completa	Front wheel assy	Roue antérieure complète	Vorder Rad Kpl.	Rueda anterior completa	
M	1	8000 H6387	1	Ruota anteriore completa	Front wheel assy	Roue antérieure complète	Vorder Rad Kpl.	Rueda anterior completa	
	2	8000 88889	1	Anello di tenuta	Seal ring	Bague d'étanchéité	Dichtungsring	Anillo de retención	
W	3	8000 13346	1	Fascia copriraggi	Rim strip	Bande	Band	Banda	
M	3	8000 43303	1	Fascia copriraggi	Rim strip	Bande	Band	Banda	
	4	8C00 92792	1	Distanziale	Spacer	Entretoise	Distanzstück	Separador	
	5	66N0 21270	1	Anello elastico	Split ring	Anneau ressort	Sprengring	Anillo elástico	
W	6	8000 H3813	1	Cerchio (1,6 x 21")	Rim (1,6 x 21")	Jante (1,6 x 21")	Felge (1,6 x 21")	Llanta (1,6 x 21")	
M	6	8000 H3138	1	Cerchio (2,75 x 17")	Rim (2,75 x 17")	Jante (2,75 x 17")	Felge (2,75 x 17")	Llanta (2,75 x 17")	
W	7	8000 92693	36	Raggio	Spoke R.	Bras D.	Speiche R.	Radio der.	
M	7	8A00 94754	18	Raggio destro	Spoke R.	Bras D.	Speiche R.	Radio der.	
M	7	8000 94754	18	Raggio sinistro	Spoke L.	Bras G.	Speiche L.	Radio izq.	
	8	Z000 48772	1	Rosetta piana	Washer	Rondelle	Scheibe	Arandela	
	9	69N4 29004	36	Nipplo	Nipple	Nipple	Nippel	Nipple	
	10	8000 A7201	1	Mozzo completo	Hub assy	Moyeau compl.	Radnabe, Kpl.	Cubo compl.	
	11	8000 A7217	1	Distanziale	Spacer	Entretoise	Distanzstück	Separador	
	12	Y000 48773	1	Vite	Screw	Vis	Schraube	Tornillo	
	13	8A00 39651	2	Cuscinetto a sfere (ø20xø42x12 mm)	Ball bearing (ø20xø42x12 mm)	Roulement à billes (ø20xø42x12 mm)	Kugellager (ø20xø42x12 mm)	Cojinete de bolas (ø20xø42x12 mm)	
A	13	8000 39651	2	Cuscinetto a sfere (ø20xø42x12 mm)	Ball bearing (ø20xø42x12 mm)	Roulement à billes (ø20xø42x12 mm)	Kugellager (ø20xø42x12 mm)	Cojinete de bolas (ø20xø42x12 mm)	
	14	8000 75042	1	Perno ruota	Axle	Pivot	Bolzen	Perno rueda	
	15	8B00 68259	1	Anello di tenuta	Seal ring (ø25xø45x7 mm)	Bague d'étanchéité	Dichtungsring	Anillo de retención	
	16	8000 99632	1	Disco freno (Ø260 mm- 3,0mm)	Brake disc (Ø260 mm- 3,0mm)	Disque frein (Ø260 mm- 3,0mm)	Bremsscheibe (Ø260 mm- 3,0mm)	Disco freno (Ø260 mm- 3,0mm)	
	17	YA00 55241	4	Vite	Screw	Vis	Schraube	Tornillo	

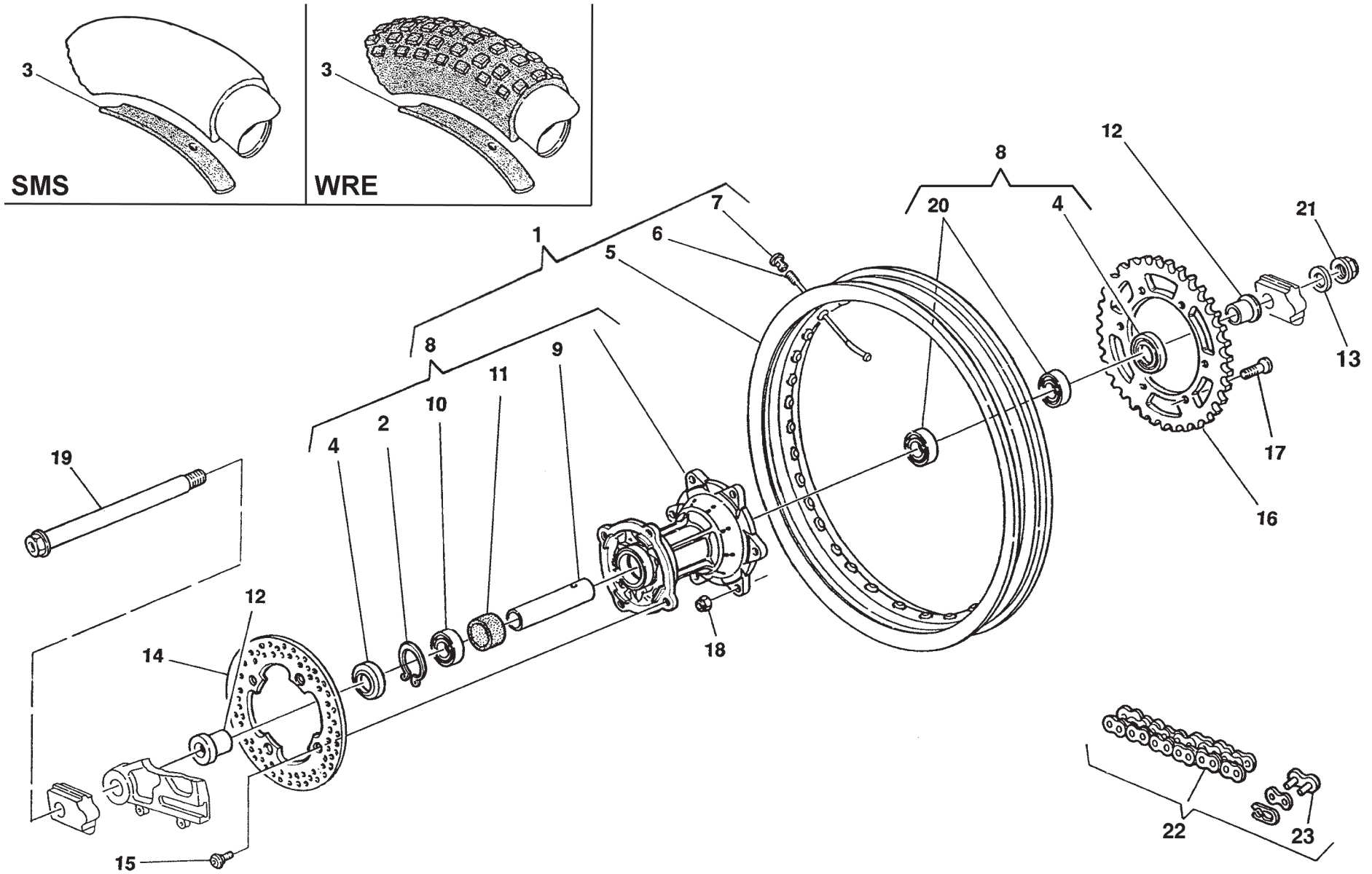



Note Notes Notas	Pos. No. Index Pos.	N. Cod. Code No. Nr. Code Code Nr N. Cod.	Q.tà Q.ty Q.te M.ge C.ad	DENOMINAZIONE	NAME	DESIGNATION	BESHREIBUNG	DENOMINACION	Validità Validity Gültig Validez
W	1	8000 H6390	1	Ruota posteriore completa	Back wheel assy	Roue postérieure complète	Hinter Rad Kpl.	Rueda posterior completa	
M	1	8000 H6388	1	Ruota posteriore completa	Back wheel assy	Roue postérieure complète	Hinter Rad Kpl.	Rueda posterior completa	
	2	66N0 21272	1	Anello elastico	Split ring	Anneau ressort	Sprengring	Anillo elástico	
W	3	8000 01688	1	Fascia copriraggi	Rim strip	Bande	Band	Banda	
M	3	8B00 82879	1	Fascia copriraggi	Rim strip	Bande	Band	Banda	
	4	8000 89572	2	Anello di tenuta	Seal ring	Bague d'étanchéité	Dichtungsring	Anillo de retención	
W	5	8000 H3814	1	Cerchio (2,15 x 18")	Rim (2,15 x 18")	Jante (2,15 x 18")	Felge (2,15 x 18")	Llanta (2,15 x 18")	
M	5	8000 H3139	1	Cerchio (4,25 x 17")	Rim (4,25 x 17")	Jante (4,25 x 17")	Felge (4,25 x 17")	Llanta (4,25 x 17")	
W	6	8000 92703	36	Raggio	Spoke	Bras	Speiche	Radio	
M	6	8000 94757	18	Raggio (L=174 mm)	Spoke (L=174 mm)	Bras (L=174 mm)	Speiche (L=174 mm)	Radio (L=174 mm)	
M	6	8000 95341	18	Raggio (L=178 mm)	Spoke (L=178 mm)	Bras (L=178 mm)	Speiche (L=178 mm)	Radio (L=178 mm)	
	7	69N4 29005	36	Nipplo	Nipple	Nipple	Nippel	Nipple	
	8	8000 A7202	1	Mozzo completo	Hub assy	Moyeau compl.	Radnabe, Kpl.	Cubo compl.	
	9	8000 A7223	1	Distanziale	Spacer	Entretoise	Distanzstück	Separador	
	10	8B00 26846	1	Cuscinetto (ø25xø47x16 mm)	Bearing (ø25xø47x16 mm)	Roulement (ø25xø47x16 mm)	Kugellager (ø25xø47x16 mm)	Cojinete (ø25xø47x16 mm)	
A	10	8D00 26846	1	Cuscinetto (ø25xø47x16 mm)	Bearing (ø25xø47x16 mm)	Roulement (ø25xø47x16 mm)	Kugellager (ø25xø47x16 mm)	Cojinete (ø25xø47x16 mm)	
	11	8000 92797	1	Porta distanziale	Spacer	Entretoise	Distanzstück	Separador	
	12	8A00 92413	2	Distanziale	Spacer	Entretoise	Distanzstück	Separador	
	13	Z000 19963	1	Rosetta	Washer	Rondelle	Scheibe	Arandela	
	14	8000 88887	1	Disco freno (ø220 mm)	Brake disc (ø220 mm)	Disque frein (ø220 mm)	Bremsscheibe (ø220 mm)	Disco freno (ø220 mm)	
	15	8000 55878	4	Vite	Screw	Vis	Schraube	Tornillo	
U	16	8000 H6184	1	Corona (Z = 49)	Ring gear (Z = 49)	Couronne (Z = 49)	Kranz (Z = 49)	Corona (Z = 49)	
	16	8000 H6386	1	Corona (Z = 49)	Ring gear (Z = 49)	Couronne (Z = 49)	Kranz (Z = 49)	Corona (Z = 49)	
	17	YC00 40796	6	Vite	Screw	Vis	Schraube	Tornillo	
	18	Y000 43928	6	Dado	Nut	Ecrou	Mutter	Tuerca	
	19	8E00 64938	1	Perno	Pin	Pivot	Bolzen	Perno	
A	19	8D00 64938	1	Perno	Pin	Pivot	Bolzen	Perno	
	20	8A00 26846	2	Cuscinetto (ø25xø47x12 mm)	Bearing (ø25xø47x12 mm)	Roulement (ø25xø47x12 mm)	Kugellager (ø25xø47x12 mm)	Cojinete (ø25xø47x12 mm)	
A	20	8C00 26846	2	Cuscinetto (ø25xø47x12 mm)	Bearing (ø25xø47x12 mm)	Roulement (ø25xø47x12 mm)	Kugellager (ø25xø47x12 mm)	Cojinete (ø25xø47x12 mm)	
	21	Z000 62613	1	Dado	Nut	Ecrou	Mutter	Tuerca	
W	22	8A00 56768	1	Catena 5/8"x1/4"(112maglie)	Chain 5/8"x1/4"(112 links)	Chaîne 5/8"x1/4"(112maillon)	Kette 5/8"x1/4"(112Schake)	Cadena 5/8"x1/4"(112malla)	
M	22	8000 56768	1	Catena 5/8"x1/4"(114maglie)	Chain 5/8"x1/4"(114 links)	Chaîne 5/8"x1/4"(114maillon)	Kette 5/8"x1/4"(114Schake)	Cadena 5/8"x1/4"(114malla)	
	23	8000 56767	1	Giunto	Coupling	Joint	Kupplung	Junta	

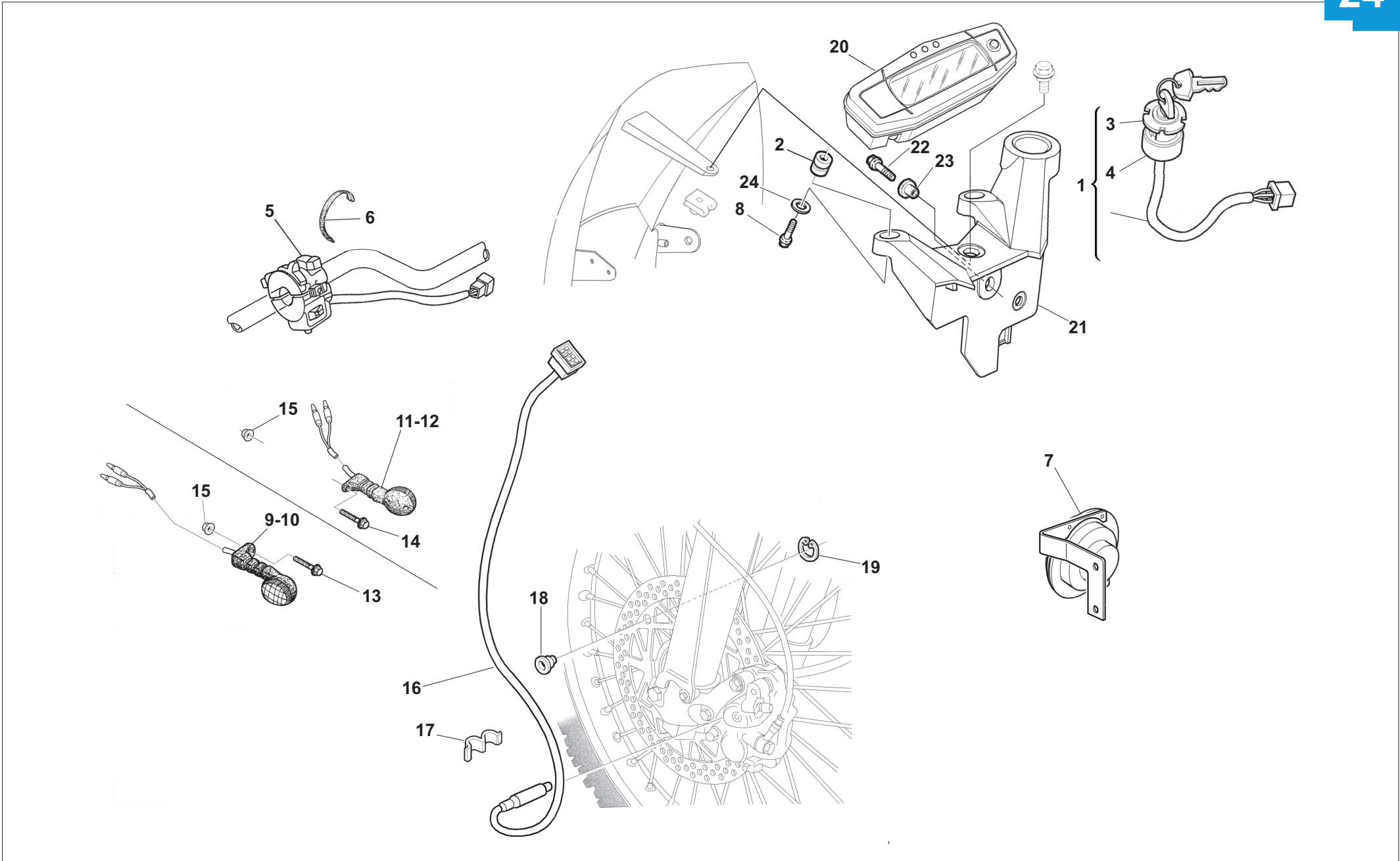



Note Notes Marke Notas	Pos. No. N. Index Pos.	N. Cod. Code No. Nr. Code Code Nr N. Cod.	Q.tà Q.ty Q.te M.ge C.ad	DENOMINAZIONE	NAME	DESIGNATION	BESHREIBUNG	DENOMINACION	Validità Validity Validité Gültig Validez
	1	8000 A8903	1	Serratura - interruttore completi	Complete lock - switch	Serrure - interrupteur complets	Schloss – Schalter komplett	Cerradura - interruptores completos	
	2	8000 H0316	2	Gommino	Rubber pad	Pièce caoutchouc	Gummistück	Junta de goma	
	3	8000 74258	1	Ghiera	Ring nut	Embout	Nutmutter	Virola	
	4	8000 50569	2	Distanziale	Spacer	Entretoise	Distanzstück	Separador	
	5	8000 96563	1	Commutatore Sx compl.	L.H. Switch compl.	Commutateur G. compl.	L. Kombischalter kpl.	Conmutador Izq. compl.	
	6	8000 71578	4	Fascetta	Clamp	Collier	Schelle	Banda	
	7	8000 H4696	1	Avvisatore acustico	Horn for front fork	Signal acoustique	Hupe	Avisador acustico	
	8	8A00 H0534	2	Vite	Screw	Vis	Schraube	Tornillo	
	9	8000 A0227	1	Indicatore ant. Dx (arancione)	Front R.H. blinker (orange)	Clignotant D. avant (orange)	Vordere R. Blinker (orange)	Intermitente D. del. (anaranjado)	
A	9	8000 H4688	1	Indicatore ant. Dx (trasparente bianco)	Front R.H. blinker (transparent white)	Clignotant D. avant (blanc transparent)	Vordere R. Blinker (transparent weiß)	Intermitente D. del. (blanco transparente)	
	10	8000 A0228	1	Indicatore ant. Sx (arancione)	Front L.H. blinker (orange)	Clignotant G. avant (orange)	Vordere L. Blinker (orange)	Intermitente I. del. (anaranjado)	
A	10	8000 H4689	1	Indicatore ant. Sx (trasparente bianco)	Front L.H. blinker (transparent white)	Clignotant G. avant (blanc transparent)	Vordere L. Blinker (transparent weiß)	Intermitente G. del. (blanco transparente)	
	11	8000 A0229	1	Indicatore post. Dx (arancione)	Front R.H. blinker (orange)	Clignotant D. avant (orange)	Vordere R. Blinker (orange)	Intermitente D. tras. (anaranjado)	
A	11	8000 H4690	1	Indicatore post. Dx (trasparente bianco)	Front R.H. blinker (transparent white)	Clignotant D. avant (blanc transparent)	Vordere R. Blinker (transparent weiß)	Intermitente D. tras. (blanco transparente)	
	12	8000 A0230	1	Indicatore post. Sx (arancione)	Front L.H. blinker (orange)	Clignotant G. avant (orange)	Vordere L. Blinker (orange)	Intermitente I. tras. (anaranjado)	
A	12	8000 H4691	1	Indicatore post. Sx (trasparente bianco)	Front L.H. blinker (transparent white)	Clignotant G. avant (blanc transparent)	Vordere L. Blinker (transparent weiß)	Intermitente G. tras. (blanco transparente)	
	13	Z000 62727	2	Vite (M6x16 mm)	Screw (M6x16 mm)	Vis (M6x16 mm)	Schraube (M6x16 mm)	Tornillo (M6x16 mm)	
	14	Z000 62728	2	Vite (M6x20 mm)	Screw (M6x20 mm)	Vis (M6x20 mm)	Schraube (M6x20 mm)	Tornillo (M6x20 mm)	
	15	Z000 44240	4	Dado	Nut	Ecrou	Mutter	Tuerca	
	16	8B00 99652	1	Sensore magnetico	Sensor	Palpeur	Sensor	Sensòr	
	17	8000 A0664	3	Molletta	Tube clip	Ressort	Feder	Resorte	
	18	8000 99775	1	Magnete	Magnet	Aimant	Magnet	Imán	
	19	66N0 21200	1	Anello elastico	Snap ring	Circlip	Sprengring	Anillo elástico	
	20	8000 H5928	1	Contachilometri digitale	Digital speedometer	Compteur-km digital	Digital Tachometer	Cuenta-kilómetros digital	
	21	8000 H0315	1	Piastra	Plate	Plaque	Platte	Placa	
	22	Z000 62726	1	Vite	Screw	Vis	Schraube	Tornillo	
	23	8000 H3017	1	Bussola	Bushing	Douille	Buchse	Buje	
	24	62ND 15548	2	Rosetta	Washer	Rondelle	Scheibe	Arandela	

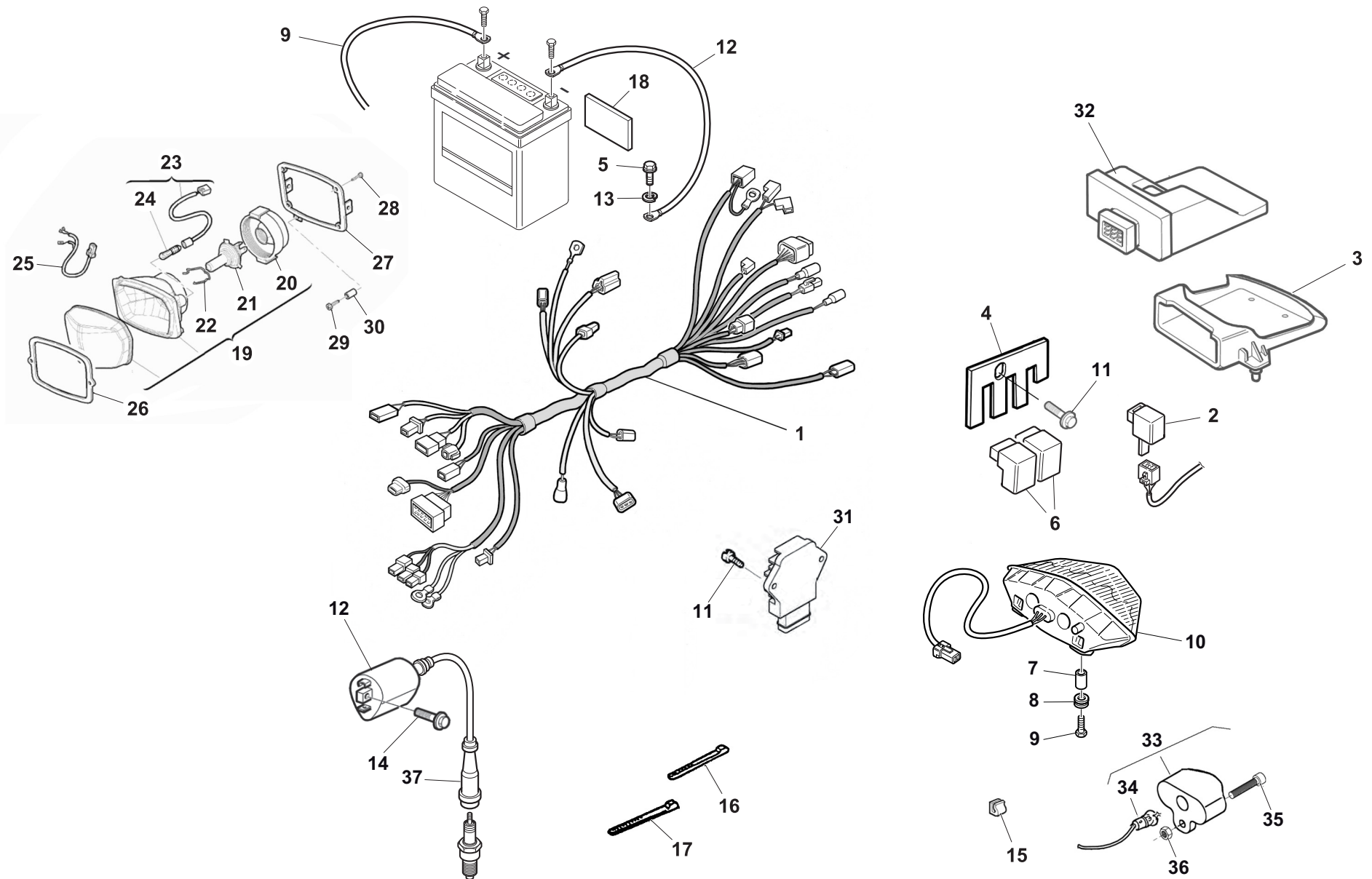



Note Notes Marke Notas	Pos. No. N. Index Pos.	N. Cod. Code No. Nr. Code Code Nr N. Cod.	Q.tà Q.ty Q.te M.ge C.ad	DENOMINAZIONE	NAME	DESIGNATION	BESHREIBUNG	DENOMINACION	Validità Validity Validité Gültig Validez
	1	8000 H5361	1	Gruppo principale cavi	Cable assy	Câbles compl.	Kabel Kpl.	Grupo principal cables	
	2	8000 H1082	1	Intermittenza	Flash device	Intermittence	Blinkgeber	Intermitencia	
	3	8000 A8703	1	Supporto centralina	E.C.U. holder	Support dispositif eletronic	Zundelektronichalterung	Soporte centralita electronica	
	4	8000 H0621	1	Piastrina	Plate	Plaque	Platte	Placa	
	5	ZA00 67997	2	Vite (M6x16)	Screw (M6x16)	Vis (M6x16)	Schraube (M6x16)	Tornillo (M6x16)	
	6	8000 A6749	2	Relè	Relay	Relais	Relais	Relais	
	7	8000 H1418	2	Distanziale	Spacer	Entretoise	Distanzstück	Separador	
	8	8000 95128	2	Gommino antivibrante	Joint en caoutch. anti-vibration	Pièce caoutchouc	Schwingungsdämpfergummi	Junta de goma anti-vibración	
	9	8000 A0953	2	Vite	Screw	Vis	Schraube	Tornillo	
	10	8000 H1418	1	Fanale posteriore completo	Tail light	Feux arrière	Hinterleuchte	Faro trasero	
	11	Z000 67977	3	Vite (M5x12)	Screw (M5x12)	Vis (M5x12)	Schraube (M5x12)	Tornillo (M5x12)	
	12	8000 A6655	1	Bobina	Coil	Bobine	Zündspule	Bobina	
	13	62ND 15535	2	Rosetta	Washer	Rondelle	Scheibe	Arandela	
	14	Z000 62727	2	Vite	Screw	Vis	Schraube	Tornillo	
	15	8000 72494	1	Molletta	Tube clip	Ressort	Feder	Resorte	
	16	8000 56444	12	Fascetta	Clamp	Collier	Schelle	Banda	
	17	8000 50005	3	Fascetta	Clamp	Collier	Schelle	Banda	
	18	8000 96739	1	Spessore elastico	Spacer	Entretoise elastique	Distanzstück	Espesor elástico	
	19	8000 H1736	1	Fanale anteriore completo	Front light	Feux antérieur	Scheinwerfer	Faro delantero	
	20	8000 H1775	1	Cuffia fanale	Boots	Poussiers	Haube	Gorro	
	21	8000 H1774	1	Lampada HS1	Lamp HS1	Lampe HS1	Lampe HS1	Lamparilla HS1	
	22	8000 H1773	1	Molla	Spring	Ressort	Feder	Resorte	
	23	8000 95886	1	Porta lampada completo	Light holder assy	Douille compl.	Glühbirnenfassung kpl.	Porta lámpara compl.	
	24	8000 36230	1	Lampada (12V-5W)	Lamp (12V-5W)	Lampe (12V-5W)	Lampe (12V-5W)	Lamparilla (12V-5W)	
	25	8000 A6094	1	Cavo fanale anteriore	Cable	Cable	Kabel	Cable	
	26	8000 A1053	1	Guarnizione	Gasket	Garniture	Dichtung	Junta	
	27	8000 A6484	1	Fissaggio fanale	Headlamp holder	Support pour phare-avant	Vorderleuchtehalterung	Soporte faro delantero	
	28	Z000 A6635	4	Vite	Screw	Vis	Schraube	Tornillo	
	29	60ND 02487	1	Vite	Screw	Vis	Schraube	Tornillo	
	30	9472 00066	1	Distanziale	Spacer	Entretoise	Distanzstück	Separador	
	31	8000 B0563	1	Regolatore di tensione compl.	Voltage rectifier assy.	Régulateur de tension compl.	Spannungsregler Kpl	Regulador de tensión compl.	
	32	8000 B1459	1	Centralina elettronica	Electronic device	Dispositif électronique	Zündelektronik	Centralita electrónica	
	33	8B00 A0212	1	Luce targa	Plate illumination	Éclairage de plaque	Kennzeichen-Beleuchtung	Iluminación matricula	









Note Notes Marka Notas	Pos. No. N. Index Pos.	N. Cod. Code No. Nr. Code Code Nr N. Cod.	Q.tà Q.ty Q.te M.ge C.ad	DENOMINAZIONE	NAME	DESIGNATION	BESHREIBUNG	DENOMINACION	Validità Validity Validité Gültig Validez
	1	8000 H6321	1	Decal per fianchetto Dx	R.H. transfer	Decalcomanie D.	Abziehbild R.	Calcomania der.	
	2	8000 H6316	1	Decal per parafango ant. centr.	Transfer	Decalcomanie	Abziehbild	Calcomania	
	3	8000 H6313	1	Decal per portafaro anteriore	Transfer	Decalcomanie	Abziehbild	Calcomania	
	4	8000 H6322	1	Decal per fianchetto Sx	L.H. transfer	Decalcomanie G.	Abziehbild L.	Calcomania izq.	
	5	8000 H6319	1	Decal per parafango ant. interno	Transfer	Decalcomanie	Abziehbild	Calcomania	
	6	8000 H6320	1	Decal per parafango post.	Transfer	Decalcomanie	Abziehbild	Calcomania	
	7	8000 H6317	1	Decal per parafango ant. dx.	Transfer	Decalcomanie	Abziehbild	Calcomania	
	8	8000 H6318	1	Decal per parafango ant. sx.	Transfer	Decalcomanie	Abziehbild	Calcomania	
	9	8000 H6323	1	Decal protezione gamba dx.	Transfer	Decalcomanie	Abziehbild	Calcomania	
	10	8000 H6324	1	Decal protezione gamba sx.	Transfer	Decalcomanie	Abziehbild	Calcomania	
	11	8000 H6314	1	Decal protezione radiatore dx.	Transfer	Decalcomanie	Abziehbild	Calcomania	
	12	8000 H6315	1	Decal protezione radiatore sx.	Transfer	Decalcomanie	Abziehbild	Calcomania	
	13	8000 H6183	1	Kit decal	Transfer kit	Jeu secalcomanie	Kit Abziehbild	Kit calcomanias	
	14	8000 A8332	1	Decal inferiore per fianchetto Dx	R.H. transfer	Decalcomanie D.	Abziehbild R.	Calcomania der.	
	15	8000 A8333	1	Decal inferiore per fianchetto Sx	L.H. transfer	Decalcomanie G.	Abziehbild L.	Calcomania izq.	

DISEGNO DRAWING DESSIN ZEICHNUNG DIBUJO	TAVOLA DRAWING TABLE BILD TABLA	INDEX NO. POS. N. INDICE	DISEGNO DRAWING DESSIN ZEICHNUNG DIBUJO	TAVOLA DRAWING TABLE BILD TABLA	INDEX NO. POS. N. INDICE	DISEGNO DRAWING DESSIN ZEICHNUNG DIBUJO	TAVOLA DRAWING TABLE BILD TABLA	INDEX NO. POS. N. INDICE	DISEGNO DRAWING DESSIN ZEICHNUNG DIBUJO	TAVOLA DRAWING TABLE BILD TABLA	INDEX NO. POS. N. INDICE	DISEGNO DRAWING DESSIN ZEICHNUNG DIBUJO	TAVOLA DRAWING TABLE BILD TABLA	INDEX NO. POS. N. INDICE	DISEGNO DRAWING DESSIN ZEICHNUNG DIBUJO	TAVOLA DRAWING TABLE BILD TABLA	INDEX NO. POS. N. INDICE
000Y A2273	1	4	64ND 20068	11	10	8000 33273	12	44	8000 47678	5	10	8000 56800	14	34	8000 67016	11A	3
1511 31701	16	34	65NO 21002	14	5	8000 33372	13	16	8000 47678	5	33	8000 57155	18	24	8000 67020	11A	6
1511 33302	16A	6	66NO 21200	24	19	8000 33372	16	18	8000 47773	3	28	8000 57196	2	11	8000 67355	17	16
1513 41401	21	10	66NO 21203	11A	11	8000 33373	14	25	8000 47822	17	19	8000 58207	14	37	8000 67997	15A	13
1513 74301	21	7	66NO 21270	22A	5	8000 34451	5	32	8000 47826	17	22	8000 59803	4	26	8000 67997	3	19
1514 10702	21	8	66NO 21272	23	2	8000 35112	21	15	8000 48245	12	36	8000 59839	16A	21	8000 68277	4	7
1617 95501	3	36	69N4 29004	22A	9	8000 35353	12	15	8000 48814	19	23	8000 59977	5	4	8000 68278	6	3
1617 95501	4	10	69N4 29005	23	7	8000 35531	14	23	8000 48814	19A	23	8000 60404	18	19	8000 68690	14	42
5524 0121A	13	18	68NO 21506	11A	18	8000 35876	9	20	8000 48856	5	28	8000 61102	5	43	8000 68860	8	2
60N1 01140	8	22	68NO 21506	7	10	8000 36023	8	9	8000 48856	6	24	8000 61313	17	15	8000 69113	21	19
60N1 02486	2	10	7640 10002	18	6	8000 36230	25	24	8000 49016	5	29	8000 61355	15A	10	8000 69149	19	7
60N1 07330	17	14	800 H1378	21	22	8000 36230	25	34	8000 49531	12	25	8000 61355	19	13	8000 69149	19A	7
60ND 02461	11	2	8000 01412	16A	12	8000 36357	5	27	8000 49767	1	8	8000 62200	5	31	8000 69150	14	26
60ND 02483	21	5	8000 01412	16A	7	8000 36380	11A	16	8000 50005	25	17	8000 62675	14	12	8000 69282	15	25
60ND 02487	25	29	8000 01688	23	3	8000 36653	6	4	8000 50569	24	4	8000 62676	14	13	8000 69282	15A	14
60ND 02504	10	2	8000 03271	6	22	8000 36786	6	20	8000 50629	2	8	8000 62725	13	9	8000 69282	16	10
60ND 02510	20	9	8000 04551	7	26	8000 37977	15	8	8000 51614	1	1	8000 62729	19	14	8000 69337	15	27
60ND 02510	20A	9	8000 06597	6	5	8000 37977	15A	26	8000 51745	5	24	8000 62729	19A	14	8000 69338	15	28
60ND 02512	5	35	8000 07719	5	15	8000 38706	9	5	8000 51746	5	25	8000 62729	22	23	8000 69429	19	17
60ND 02514	5	37	8000 10314	2	3	8000 38707	7	24	8000 53249	2	28	8000 62796	15	13	8000 69429	19A	17
60ND 02515	5	36	8000 12041	12	5	8000 38707	9	7	8000 53259	18	21	8000 62796	15A	5	8000 69549	13	2
60ND 02518	5	21	8000 13346	22A	3	8000 38708	9	3	8000 53259	22	20	8000 64296	2	27	8000 69551	16B	6
60ND 07305	13	13	8000 18922	10	18	8000 38767	16A	5	8000 53322	6	6	8000 65884	9	6	8000 70215	9	16
60ND 07330	25	35	8000 19789	3	33	8000 38956	16A	9	8000 53324	5	6	8000 65921	9	13	8000 70216	9	15
60ND 07335	5	19	8000 19789	8	25	8000 38957	16A	10	8000 53340	6	12	8000 65922	4	9	8000 70217	9	14
61ND 15062	18	7	8000 21480	18	25	8000 39630	2	16	8000 54427	5	30	8000 65923	4	2	8000 70467	7	4
61ND 15192	25	36	8000 21480	22	6	8000 39651	22A	13	8000 54507	7	9	8000 65935	4	4	8000 70468	7	17
62NO 15676	2	29	8000 21939	5	7	8000 40449	8	14	8000 55134	19	5	8000 65955	8	21	8000 70549	7	7
62NO 15678	5	49	8000 22551	18	3	8000 40718	15A	17	8000 55134	19A	5	8000 65975	9	8	8000 70550	7	6
62N3 15516	13	4	8000 27960	6	21	8000 41459	14	16	8000 55241	18	11	8000 66651	14	19	8000 70551	7	5
62ND 15504	14	17	8000 28553	3	35	8000 42643	5	26	8000 55520	15	9	8000 66652	14	30	8000 70552	7	12
62ND 15508	11	6	8000 28929	20	7	8000 42781	16A	2	8000 55520	15A	25	8000 66774	17	10	8000 70635	2	17
62ND 15519	10	9	8000 28929	20A	7	8000 43303	22A	3	8000 55588	7	28	8000 66946	11A	15	8000 70966	15	5
62ND 15535	25	13	8000 28959	6	2	8000 43382	5	5	8000 55878	23	15	8000 66952	5	11	8000 70966	15A	28
62ND 15547	13	17	8000 29089	7	16	8000 43391	14	22	8000 55903	18	13	8000 66954	7	23	8000 71578	24	6
62ND 15547	19	31	8000 31744	8	24	8000 43720	1	11	8000 56444	21	13	8000 66962	9	21	8000 71620	16	4
62ND 15547	19A	25	8000 31768	8	7	8000 43824	1	9	8000 56444	25	16	8000 66968	6	7	8000 71621	16	3
62ND 15548	19	25	8000 32065	16A	3	8000 43928	12	39	8000 56460	10	19	8000 66972	6	18	8000 71741	12	22
62ND 15548	24	24	8000 32388	16	6	8000 45499	21	18	8000 56462	4	22	8000 66973	6	13	8000 72168	16A	4
62ND 15549	13	10	8000 32867	12	23	8000 46225	9	10	8000 56722	10	14	8000 67011	9	18	8000 72431	9	12
62ND 15673	4	15	8000 33054	1	10	8000 46428	7	18	8000 56767	23	23	8000 67013	11A	8	8000 72494	25	15
64ND 20048	14	18	8000 33109	12	7	8000 47496	9	2	8000 56768	23	22	8000 67015	11A	2	8000 72641	13	3

DISEGNO DRAWING DESSIN ZEICHNUNG DIBUJO	TAVOLA DRAWING TABLE BILD TABLA	INDEX NO. POS. N. INDICE	DISEGNO DRAWING DESSIN ZEICHNUNG DIBUJO	TAVOLA DRAWING TABLE BILD TABLA	INDEX NO. POS. N. INDICE	DISEGNO DRAWING DESSIN ZEICHNUNG DIBUJO	TAVOLA DRAWING TABLE BILD TABLA	INDEX NO. POS. N. INDICE	DISEGNO DRAWING DESSIN ZEICHNUNG DIBUJO	TAVOLA DRAWING TABLE BILD TABLA	INDEX NO. POS. N. INDICE	DISEGNO DRAWING DESSIN ZEICHNUNG DIBUJO	TAVOLA DRAWING TABLE BILD TABLA	INDEX NO. POS. N. INDICE	DISEGNO DRAWING DESSIN ZEICHNUNG DIBUJO	TAVOLA DRAWING TABLE BILD TABLA	INDEX NO. POS. N. INDICE
8000 72800	8	6	8000 76283	16	2	8000 83090	3	11	8000 92693	22A	7	8000 A0664	24	17	8000 A8332	26	4
8000 72874	16	28	8000 76605	9	12	8000 83092	3	20	8000 92703	23	6	8000 A0680	20	10	8000 A8332	27	4
8000 72884	16	22	8000 77347	9	1	8000 83095	11A	5	8000 92797	23	11	8000 A0680	20A	10	8000 A8332	27A	4
8000 73348	16A	1	8000 77360	15	3	8000 83107	3	3	8000 92820	7	14	8000 A0864	19	26	8000 A8332	27B	14
8000 73394	16A	20	8000 77360	15A	31	8000 83109	3	10	8000 92896	5	18	8000 A0864	19A	26	8000 A8333	26	5
8000 73649	8	23	8000 77362	15	2	8000 83110	3	9	8000 94625	13	15	8000 A0930	22	16	8000 A8333	27	5
8000 73650	8	26	8000 77362	15A	29	8000 83111	3	7	8000 94653	2	30	8000 A0931	22	19	8000 A8333	27A	5
8000 73834	19	29	8000 77378	15	7	8000 83113	3	22	8000 94680	4	34	8000 A0932	22	18	8000 A8333	27B	15
8000 73834	19A	29	8000 77378	15A	24	8000 83114	3	14	8000 94681	4	21	8000 A0953	25	9	8000 A8423	20	18
8000 74258	24	3	8000 77841	5	20	8000 83115	3	5	8000 94721	10	12	8000 A1053	25	26	8000 A8423	20A	18
8000 74758	6	15	8000 78031	10	20	8000 83116	3	16	8000 94754	22A	7	8000 A1138	22	9	8000 A8446	2	19
8000 74815	16	14	8000 78031	5	14	8000 83118	3	25	8000 94757	23	6	8000 A1139	22	10	8000 A8447	2	14
8000 74836	5	17	8000 78164	18	23	8000 83119	3	21	8000 94849	18	20	8000 A1242	2	1	8000 A8674	10	4
8000 75042	22A	14	8000 78915	17	18	8000 83121	3	24	8000 95128	25	8	8000 A1406	7	27	8000 A8676	10	8
8000 75270	25	37	8000 79004	15A	22	8000 85932	18	22	8000 95341	23	6	8000 A3555	3	26	8000 A8688	12	43
8000 75271	17	6	8000 79005	15	6	8000 86004	19	34	8000 95886	25	23	8000 A3556	3	27	8000 A8689	12	40
8000 75310	17	8	8000 79005	15A	23	8000 86004	19A	13	8000 96563	24	5	8000 A3557	3	30	8000 A8703	25	3
8000 75415	5	48	8000 79006	15	14	8000 86981	2	15	8000 96739	10	17	8000 A4506	2	4	8000 A8717	12	33
8000 75962	8	1	8000 79006	15A	32	8000 87038	15	10	8000 96739	25	18	8000 A4562	20	12	8000 A8762	17	9
8000 75963	8	11	8000 79007	15	15	8000 87038	15A	27	8000 96907	14	8	8000 A4562	20A	12	8000 A8792	19	1
8000 75964	8	10	8000 79007	15A	30	8000 87072	4	32	8000 96908	14	8	8000 A4875	19	24	8000 A8792	19A	1
8000 75965	8	8	8000 79008	15	29	8000 87152	18	17	8000 96934	22	17	8000 A4875	19A	24	8000 A8903	24	1
8000 75966	8	5	8000 79008	15A	34	8000 87243	14	2	8000 97726	15	20	8000 A6090	21	12	8000 A8985	5	34
8000 75967	8	3	8000 79015	1	5	8000 87276	17	20	8000 97726	15A	20	8000 A6094	25	25	8000 A8986	2	22
8000 75968	8	12	8000 79016	1	6	8000 87745	15	31	8000 97727	15	12	8000 A6484	25	27	8000 A9204	17	3
8000 75969	8	20	8000 79017	1	7	8000 87745	15A	36	8000 97727	15A	19	8000 A6655	25	12	8000 A9205	17	7
8000 75970	8	19	8000 79065	22	21	8000 87813	5	44	8000 98431	1	14	8000 A6662	11	3	8000 A9206	10	1
8000 75971	8	18	8000 79066	22	22	8000 88597	12	45	8000 99674	22	11	8000 A6749	25	6	8000 A9231	18	16
8000 75972	8	17	8000 79067	22	2	8000 88810	2	7	8000 99632	22A	16	8000 A7201	22A	10	8000 A9345	12	34
8000 75973	8	16	8000 79068	22	3	8000 88822	7	8	8000 99749/1	2	2	8000 A7202	23	8	8000 A9447	18	14
8000 75974	8	15	8000 79069	22	4	8000 88828	5	3	8000 99749/2	2	2	8000 A7217	22A	11	8000 A9448	18	8
8000 75975	8	13	8000 79070	22	5	8000 88887	23	14	8000 99749/3	2	2	8000 A7223	23	9	8000 A9449	18	9
8000 75984	4	20	8000 79077	4	25	8000 88889	22A	2	8000 99767	5	16	8000 A7633	18	10	8000 A9519	10	10
8000 76002	16	29	8000 79560	2	25	8000 89030	1	3	8000 99775	24	18	8000 A7635	18	5	8000 A9520	10	11
8000 76032	18	15	8000 79561	4	1	8000 89572	23	4	8000 99859	22	14	8000 A7970	4	24	8000 A9751	1	2
8000 76074	5	40	8000 83043	5	46	8000 89813	17	11	8000 A0227	24	9	8000 A7971	4	36	8000 A9753	17	5
8000 76075	5	41	8000 83049	3	31	8000 89814	17	23	8000 A0228	24	10	8000 A7972	4	25	8000 B0495	11	1
8000 76076	5	42	8000 83056	2	23	8000 89815	17	12	8000 A0229	24	11	8000 A7973	4	36	8000 B0563	25	31
8000 76079	11	8	8000 83066	2	5	8000 90093	15	19	8000 A0230	24	12	8000 A7974	4	24	8000 B0789	12	1
8000 76132	9	17	8000 83068	2	20	8000 90093	15A	3	8000 A0267	14	11	8000 A7975	4	25	8000 B0790	12	3
8000 76133	9	19	8000 83071	2	6	8000 92215	4	36	8000 A0528	20	8	8000 A8040	20	5	8000 B0791	12	4
8000 76262	5	38	8000 83085	7	3	8000 92216	4	24	8000 A0528	20A	8	8000 A8040	20A	5	8000 B0792	12	9

DISEGNO DRAWING DESSIN ZEICHNUNG DIBUJO	TAVOLA DRAWING TABLE BILD TABLA	INDEX NO. POS. N. INDICE	DISEGNO DRAWING DESSIN ZEICHNUNG DIBUJO	TAVOLA DRAWING TABLE BILD TABLA	INDEX NO. POS. N. INDICE	DISEGNO DRAWING DESSIN ZEICHNUNG DIBUJO	TAVOLA DRAWING TABLE BILD TABLA	INDEX NO. POS. N. INDICE	DISEGNO DRAWING DESSIN ZEICHNUNG DIBUJO	TAVOLA DRAWING TABLE BILD TABLA	INDEX NO. POS. N. INDICE	DISEGNO DRAWING DESSIN ZEICHNUNG DIBUJO	TAVOLA DRAWING TABLE BILD TABLA	INDEX NO. POS. N. INDICE	DISEGNO DRAWING DESSIN ZEICHNUNG DIBUJO	TAVOLA DRAWING TABLE BILD TABLA	INDEX NO. POS. N. INDICE
8000 B0793	12	10	8000 H2159	11A	12	8000 H4688	24	9	8000 H6084	15A	11	80A0 89953	14	38	8A00 53248	5	8
8000 B0794	12	11	8000 H2160	11A	14	8000 H4689	24	10	8000 H6087	27A	11	80A0 89962	14	37	8A00 54164	5	9
8000 B0795	12	12	8000 H3006	19	22	8000 H4690	24	11	8000 H6088	27A	2	80A0 A0633	15A	8	8A00 56768	23	22
8000 B0796	12	13	8000 H3006	19A	22	8000 H4691	24	12	8000 H6158	11A	13	80A0 A4198	19	6	8A00 57024	3	8
8000 B0797	12	14	8000 H3011	21	1	8000 H4696	24	7	8000 H6183	27B	13	80A0 A5507	20	1	8A00 61261	8	4
8000 B0798	12	16	8000 H3013	13	7	8000 H4701	22	17	8000 H6184	23	16	80A0 A5507	20A	1	8A00 62802	16	17
8000 B0799	12	17	8000 H3017	20	20	8000 H4758	13	1	8000 H6305	19A	9	80A0 A5977	20	17	8A00 65845	7	22
8000 B0800	12	18	8000 H3017	20A	20	8000 H4858	14	14	8000 H6306	19A	10	80A0 A5977	20A	17	8A00 65895	9	22
8000 B0801	12	19	8000 H3017	24	23	8000 H5345	1	16	8000 H6313	27B	3	80A0 A5978	20	16	8A00 65955	8	21
8000 B0802	12	20	8000 H3020	21	3	8000 H5346	1	15	8000 H6314	27B	11	80A0 A5978	20A	16	8A00 65955	8	21
8000 B0805	12	28	8000 H3033	16	21	8000 H5349	14	1	8000 H6315	27B	12	80A0 H0167	3	12	8A00 66953	5	13
8000 B0806	12	29	8000 H3033	16	27	8000 H5357	19	9	8000 H6316	27B	2	80A0 H0168	3	17	8A00 67997	15A	9
8000 B0807	12	31	8000 H3034	16	25	8000 H5358	19	10	8000 H6317	27B	7	80A0 H1931	26	3	8A00 69125	18	2
8000 B0808	12	32	8000 H3138	22A	6	8000 H5359	20	21	8000 H6318	27B	8	80A0 H1931	27	3	8A00 69282	16	24
8000 B1057	20	11	8000 H3139	23	5	8000 H5360	20	22	8000 H6319	27B	5	80A0 H1931	27A	3	8A00 69315	15	23
8000 B1057	20A	11	8000 H3210	16B	1	8000 H5361	25	1	8000 H6320	27B	6	80B0 35357	12	8	8A00 69315	15A	6
8000 B1459	25	32	8000 H3511	14	27	8000 H5366	4	19	8000 H6321	27B	1	80B0 83024	4	8	8A00 71154	5	2
8000 H0044	17	1	8000 H3813	22A	6	8000 H5369	4	37	8000 H6322	27B	4	80B0 83076	3	34	8A00 74794	16	1
8000 H0315	24	21	8000 H3814	23	5	8000 H5371	4	23	8000 H6323	27B	9	80C0 69338	15	28	8A00 75153	16A	14
8000 H0316	24	2	8000 H3866	18	1	8000 H5373	11A	1	8000 H6324	27B	10	80C0 69338	15A	12	8A00 75432	14	20
8000 H0417	2	9	8000 H3975	19	9	8000 H5381	1	17	8000 H6326	21	21	80C0 74816	16	15	8A00 76024	22	1
8000 H0464	5	1	8000 H3975	19	9	8000 H5399	19	12	8000 H6386	23	16	80C0 H0198	19	16	8A00 76055	18	6
8000 H0621	25	4	8000 H3976	19	10	8000 H5399	19A	12	8000 H6387	22A	1	80C0 H0198	19A	16	8A00 78996	15A	18
8000 H0938	3	1	8000 H3976	19	10	8000 H5435	2	21	8000 H6388	23	1	80C0 H0878	19	3	8A00 81900	10	15
8000 H0995	17	2	8000 H3977	20	21	8000 H5722	14	39	8000 H6389	22A	1	80C0 H1411	6	10	8A00 83056	2	24
8000 H1082	25	2	8000 H3977	20	21	8000 H5728	7	19	8000 H6390	23	1	8661 0191A	19	2	8A00 83068	2	20
8000 H1285	6	14	8000 H3977	20A	21	8000 H5730	4	18	8000 H6398	1	17	8661 0191A	19A	2	8A00 87054	17	4
8000 H1376	21	21	8000 H3978	20	22	8000 H5752	15	21	8000 H6505	4	30	8A00 04883	4	3	8A00 87717	15	16
8000 H1405	19	28	8000 H3978	20	22	8000 H5757	15	17	8000 H6506	4	17	8A00 19946	11A	9	8A00 87717	15A	4
8000 H1405	19A	28	8000 H3978	20A	22	8000 H5757	15A	1	8000 H6507	4	31	8A00 20182	16	35	8A00 88746	17	13
8000 H1418	25	10	8000 H4027	20	14	8000 H5758	15	18	8000 H6508	4	16	8A00 23186	21	2	8A00 92413	23	12
8000 H1418	25	7	8000 H4027	20A	14	8000 H5758	15A	2	8010 H2395	14	32	8A00 25044	7	20	8A00 94754	22A	7
8000 H1673	17	21	8000 H4165	14	29	8000 H5759	15	1	80A0 12032	12	6	8A00 26846	23	20	8A00 97976	14	15
8000 H1686	10	13	8000 H4180	22	11	8000 H5760	15	22	80A0 42349	20	15	8A00 31386	7	15	8A00 A7171	1	13
8000 H1736	25	19	8000 H4192	7	11	8000 H5761	15	4	80A0 42349	20A	15	8A00 35371	12	2	8A00 A8423	16B	7
8000 H1773	25	22	8000 H4193	7	13	8000 H5928	24	20	80A0 47665	7	25	8A00 36849	7	21	8A00 A8423	20	25
8000 H1774	25	21	8000 H4474	16B	3	8000 H5948	15A	7	80A0 59299	16	11	8A00 36984	16	32	8A00 A8423	20A	25
8000 H1775	25	20	8000 H4476	16B	2	8000 H6016	26	2	80A0 65535	19	8	8A00 38287	11A	17	8A00 A8673	10	3
8000 H1777	10	16	8000 H4503	20	2	8000 H6017	26	1	80A0 73456	16	8	8A00 39651	22A	13	8A00 A8675	10	7
8000 H1917	19	15	8000 H4503	20A	2	8000 H6018	27	2	80A0 74388	16	7	8A00 40433	2	26	8A00 A8692	12	41
8000 H1917	19A	15	8000 H4520	20	3	8000 H6019	27	1	80A0 75097	15	11	8A00 42349	10	21	8A00 H0428	6	1
8000 H2099	22	15	8000 H4520	20A	3	8000 H6084	15	27	80A0 75097	15A	21	8A00 46226	9	9	8A00 H0534	24	8

DISEGNO DRAWING DESSIN ZEICHNUNG DIBUJO	TAVOLA DRAWING TABLE BILD TABLA	INDEX NO. POS. N. INDICE	DISEGNO DRAWING DESSIN ZEICHNUNG DIBUJO	TAVOLA DRAWING TABLE BILD TABLA	INDEX NO. POS. N. INDICE	DISEGNO DRAWING DESSIN ZEICHNUNG DIBUJO	TAVOLA DRAWING TABLE BILD TABLA	INDEX NO. POS. N. INDICE	DISEGNO DRAWING DESSIN ZEICHNUNG DIBUJO	TAVOLA DRAWING TABLE BILD TABLA	INDEX NO. POS. N. INDICE	DISEGNO DRAWING DESSIN ZEICHNUNG DIBUJO	TAVOLA DRAWING TABLE BILD TABLA	INDEX NO. POS. N. INDICE	DISEGNO DRAWING DESSIN ZEICHNUNG DIBUJO	TAVOLA DRAWING TABLE BILD TABLA	INDEX NO. POS. N. INDICE
8A00	H1673	22.....13	8D00	59802	4.....27	Y000	55902	18.....4	Z000	62726	21.....20	ZA00	37283	19A.....27			
8A00	H3019	16.....31	8D00	64938	23.....19	Y000	73140	14.....6	Z000	62726	24.....22	ZA00	37947	13.....11			
8AA0	A0872	4.....33	8D00	68157	16A.....8	Y000	74372	16A.....13	Z000	62727	18.....18	ZA00	62797	16B.....4			
8AB0	76028	16.....19	8D00	68860	8.....2	YA00	55241	22A.....17	Z000	62727	19.....32	ZA00	67545	12.....35			
8AC0	66947	6.....17	8D00	73623	13.....6	YA00	74372	16A.....22	Z000	62727	19A.....8	ZA00	67545	21.....6			
8AC0	H0525	19.....3	8E00	01049	11A.....10	YC00	40796	23.....17	Z000	62727	24.....13	ZA00	67545	6.....8			
8AC0	H0525	19A.....3	8E00	04551	7.....26	YN00	73458	14.....3	Z000	62727	25.....14	ZA00	67997	16.....26			
8B00	26846	23.....10	8E00	18282	11A.....4	YP00	73458	14.....4	Z000	62727	6.....16	ZA00	67997	25.....5			
8B00	42029	16A.....11	8E00	32069	5.....23	Z000	19963	23.....13	Z000	62728	19.....18	ZA00	67997	3.....15			
8B00	43715	4.....29	8E00	34292	4.....5	Z000	20536	16.....12	Z000	62728	19.....19	ZA00	67997	3.....32			
8B00	57022	3.....4	8E00	64938	23.....19	Z000	24962	11.....4	Z000	62728	19A.....18	ZA00	69138	16A.....19			
8B00	64988	2.....12	8E00	68860	8.....2	Z000	30319	11A.....20	Z000	62728	19A.....19	ZB00	62733	12.....38			
8B00	65955	8.....21	8E00	69429	19.....20	Z000	30319	14.....35	Z000	62728	24.....14	ZB00	67545	4.....12			
8B00	66525	15A.....16	8E00	69429	19A.....20	Z000	36137	16.....20	Z000	62728	4.....13	ZB00	69056	14.....21			
8B00	68259	22A.....15	8E00	99475	13.....12	Z000	36467	20.....19	Z000	62728	6.....19	ZC00	67997	16.....23			
8B00	68860	8.....2	8F00	28960	4.....6	Z000	36467	20A.....19	Z000	62728	7.....1	ZD00	62797	16A.....16			
8B00	70379	21.....9	8F00	68860	8.....2	Z000	36467	21.....14	Z000	62728	9.....11	ZE00	67545	16.....36			
8B00	73458	14.....4	8G00	04551	7.....26	Z000	40717	19.....30	Z000	62729	17.....17	ZE00	67997	3.....29			
8B00	76025	22.....8	8H00	99475	5.....45	Z000	40717	19A.....30	Z000	62729	3.....23	ZF00	67997	3.....13			
8B00	78997	15A.....33	8S00	67545	6.....23	Z000	40718	13.....8	Z000	62729	4.....28	ZH00	67545	18.....12			
8B00	82879	23.....3	8T00	68873	20.....13	Z000	42022	16A.....18	Z000	62729	6.....11	ZJ00	67545	20.....4			
8B00	83068	2.....20	8T00	68873	20A.....13	Z000	42022	16B.....5	Z000	62729	6.....9	ZJ00	67545	20A.....4			
8B00	94808	21.....11	8W00	68873	10.....8	Z000	42023	11.....7	Z000	62730	9.....4	ZK00	69056	2.....13			
8B00	99652	24.....16	9472	00035	10.....5	Z000	42023	16A.....15	Z000	62731	4.....11	ZK00	69056	22.....12			
8B00	A0212	25.....33	9472	00066	25.....30	Z000	42643	5.....12	Z000	62795	16.....30	ZS00	67545	4.....14			
8B00	A0702	20.....6	HMAK	R7AU0	1.....12	Z000	44240	19.....33	Z000	62797	16B.....4						
8B00	A0702	20A.....6	U000	46893	14.....41	Z000	44240	19A.....6	Z000	67977	25.....11						
8B00	A8421	19.....11	U000	46893	21.....4	Z000	44240	24.....15	Z000	67997	10.....6						
8B00	A8421	19A.....11	U000	46893	21.....16	Z000	48411	13.....5	Z000	67997	15.....24						
8B00	A8423	13.....14	U000	55134	20.....23	Z000	48772	22A.....8	Z000	67997	16.....9						
8B00	A8692	12.....42	U000	55134	20A.....23	Z000	48814	12.....37	Z000	67997	3.....2						
8B00	H4858	14.....14	U000	57155	22.....7	Z000	48814	7.....2	Z000	67997	3.....6						
8BA0	70558	15A.....15	U000	60873	20.....24	Z000	59801	4.....35	Z000	67997	5.....22						
8C00	04551	7.....26	U000	60873	20A.....24	Z000	61313	16.....13	Z000	69056	14.....33						
8C00	26846	23.....20	U000	62727	21.....17	Z000	61313	19.....4	Z000	71623	16.....5						
8C00	41750	5.....39	Y000	43928	14.....24	Z000	61313	19A.....4	Z000	84658	15.....32						
8C00	68860	8.....2	Y000	43928	14.....28	Z000	61357	14.....31	Z000	87736	15.....30						
8C00	69429	19.....21	Y000	43928	14.....5	Z000	62400	16.....16	Z000	87736	15A.....35						
8C00	69429	19A.....21	Y000	43928	16.....33	Z000	62613	23.....21	Z000	98213	5.....47						
8C00	92792	22A.....4	Y000	43928	2.....18	Z000	62725	11A.....19	Z000	A6635	25.....28						
8D00	10789	11A.....7	Y000	43928	23.....18	Z000	62725	14.....36	ZA00	01815	14.....9						
8D00	26846	23.....10	Y000	48773	22A.....12	Z000	62726	14.....40	ZA00	37283	19.....27						